



ROHDE&SCHWARZ

SERVICE DOCUMENTS

E 6 GHZ Board

1084.9600.00

Contents

7	Testing and Repair of the Board	4
7.1	Function Description	4
7.1.1	Input REF600	4
7.1.2	Input IQ300	4
7.1.3	IF900 - IF Signal of Mixer2	5
7.1.4	LO Conditioning for Mixer 1	5
7.1.5	RF Path at IF Output of Mixer1	5
7.1.6	Filter Bank	5
7.1.7	RF Level Control	6
7.1.8	Diagnosis	6
7.2	Measuring Instruments and Auxiliary Means	6
7.3	Troubleshooting	6
7.3.1	RF Level	7
7.3.2	Spectral Purity of Output Signal IQOUT6	8
7.4	Testing and Adjustment	8
7.4.1	Testing the Data Transmission	8
7.4.2	Testing the Reference Voltages	9
7.4.3	Testing the Operating Points of the Amplifier Stages ..	9
7.4.4	Testing the Switching Voltages of RFSWITCH 1	10
7.4.5	Testing the Switching Voltages of RFSWITCH 2	10
7.4.6	Testing the Tuning Voltages	10
7.4.7	Testing the RF Signal Paths	11
7.4.8	Adjusting the Drain Current of A510 in the POWER UNIT..	11
7.4.9	Adjusting the Reference 10 V	11
7.4.10	RF-DC-ZERO Adjustment at Output Detector	11
7.4.11	Adjusting the RF Level Linearity	12
7.4.12	Adjusting the IF900 Level	12
7.4.13	Calibration of the Tunable Filters	12
7.4.14	Tables and Interfaces	12
7.4.14.1	Diagnosis	12
7.4.14.2	Serial Data (Subaddress 1)	15
7.5	Disassembly and Assembly	16
7.6	External Interfaces	17

Parts list
Coordinates list
Circuit diagram
Component location plan

7. Testing and Repair of the Board

7.1. Function Description

The E6GHZ board extends the frequency range of the SMIQ03 by the range 3300 to 6400 MHz.

The IQ300 signal at X504 from the IQMOD module (300 MHz, IQ-modulated) is up-converted to 900 MHz using MIXER2 (IF900). Unwanted mixer products at the output of MIXER2 are filtered off by means of bandpass filters.

The REF600 signal at X502 from the reference/step synthesis (600 MHz) is doubled and serves as LO for MIXER2 (1200 MHz).

MIXER1 converts IF900 to the range 3300 to 6400 MHz. The LO signal (4200 to 6000 MHz) for MIXER1 is generated by doubling the FIQOUT signal of the IQMOD at X505.

Unwanted mixer products at the output of MIXER1 are suppressed by means of bandpass filters and a switched filter bank containing bandpass filters and tunable highpass and lowpass filters in 4 paths.

A level control element (LEVEL PRESET) preceding the filter bank permits to set the operating point of the amplitude modulator (instrument calibration routine Level Preset). Following the filter bank, the output level of the instrument is set by the amplitude modulator.

The thin-film unit POWERUNIT includes the output stage and a detector, which detects the output level of the instrument for the frequency range 3300 to 6400 MHz. There, the signal from the IQMOD (FIQOUT at X505) is also directly through-connected to the module output (IQOUT6 at X506) for frequencies < 3300 MHz.

7.1.1. Input REF600

The REF600 signal at X502 (600 MHz, 13 dBm) is split up via a power divider, taken via an amplifier and again provided as output signal at X501 REF600E for IQMOD (600 MHz, 13 dBm) and doubled as LO signal for MIXER2 to 1200 MHz, filtered and amplified to a controlled LO level of 17 dBm.

7.1.2. Input IQ300

The IQ300 signal at X504 (300 MHz, -9 dBm) is split up via a power divider, taken via an amplifier and again provided as output signal at X503 IQ300AUX (300 MHz, -9 dBm) and is used as RF signal for MIXER2 (level -12 dBm).

7.1.3. IF900 - IF Signal of Mixer2

The IF signal of MIXER2 (900 MHz) is filtered and amplified and taken to the RF connector of MIXER1 (level -12 dBm). The RF level at X2 is adjusted to -12 dBm by means of LEVEL IF900 (R848).

7.1.4. LO Conditioning for Mixer 1

For LO conditioning, the FIQOUT signal is doubled by the POWERUNIT at X9 from 2100 to 3000 MHz to 4200 to 6000 MHz. For suppression of subharmonics, the lowpass filter LP5100 is cut in at frequencies at FIQOUT < 5100 MHz. A level control ensures a constant LO level at X1 (17 dBm).

7.1.5. RF Path at IF Output of Mixer1

The mixer output signal (-18 dBm) is taken via amplifiers and filters to the level preset control element and via the filter bank and the AM modulator to the input X6 of the POWERUNIT. The amplifier stages have a gain (S21) of approx. 8 dB each, thus compensating for the filter attenuations.

7.1.6. Filter Bank

The tunable filters are set according to the frequency; the necessary data is determined in the module test in the production and contained in the EEPROM of the module.

Each tracking filter is driven by a tuning voltage. IQFILT1 and IQFILT2 drive the lowpass filters, IQFILH1 and IQFILH2 the highpass filters. In the deactivated filter paths, the respective lowpass filters are set to minimum and the highpass filters to maximum tuning voltage via selector switches (0 or 20 V).

The four control bits FILOFF1 to FILOFF4 check the selector switches and the ON/OFF functions of the filter paths.

There are four frequency ranges:

Frequency range	SMIQ output frequency	FIQOUT from IQMOD	LO frequency Mixer 1	Sideband	Control signal LP5100_ON
FB1	3300 to 4200 MHz	2100 to 2550 MHz	4200 to 5100 MHz	lower	L
FB2	4200 to 5100 MHz	2550 to 3000 MHz	5100 to 6000 MHz	lower	H
FB3	5100 to 6000 MHz	2100 to 2550 MHz	4200 to 5100 MHz	upper	L
FB4	6000 ... 6400 MHz	2550 ... 2750 MHz	5100 ... 5500 MHz	upper	H

7.1.7. RF Level Control

The command value for the amplitude modulation ($f > 3.3$ GHz) and the level control is applied to the module via X500.A2 UREFAM. At frequencies < 3.3 GHz, the control bit AM_ON switches over to a command value generated on the module, since the amplitude modulation is already generated on the IQMOD module. The temperature-compensated and linearized detector output voltage is applied as actual value to the control amplifier N29, which drives the AM modulator.

The level linearity is adjusted using trimmers RF DC ZERO (R394) and DETECTOR OFFSET (R173). The nominal value for the level control is set via D/A converter D2. The control bandwidth is switched over via control bit AM_SLOW_ON. For the IQ mode or in the operating mode "ALC OFF MODE TABLE", the AM modulator is controlled by the level D/A converter (ALC_ON = Low, DETOUT_ON = Low), N29 will then operate as amplifier.

7.1.8. Diagnosis

Diagnosis voltages determined via RF rectifiers feature large tolerances and can only be used as indicators (RF level present / not present). RF test points without directional couplers do not detect the forward power, but the RF voltage, which is to a large extent dependent on the matching (impedance) and therefore features large fluctuations versus the frequency.

7.2. Measuring Instruments and Auxiliary Means

- DC voltmeter, ammeter (e.g. UDS5)
- RF power meter (e.g. NRVD)
- RF spectrum analyzer up to 20 GHz (e.g. FSM)
- RF network analyzer up to 8 GHz (e.g. ZVC)

7.3. Troubleshooting

For first error diagnosis it is recommended to use the test program included in the service kit, which offers comprehensive possibilities.

Before starting more detailed troubleshooting in the RF paths, it is recommended to check the serial interface for correct data transmission and the diagnosis, reference, operating point and control voltages for the correct value.

7.3.1. RF Level

Error message:

ALC LOOP FAILURE

No level

or

**fault during
Level Preset calibration
at frequencies > 3.3 GHz**

**Level cannot be varied at all
frequencies > 3.3 GHz**

**No level in only one frequency
range FB1 to FB4 of the filter
bank**

**Level linearity out of
tolerance**

First check at which frequencies the level control does not work. To this end, check the frequency ranges FB1 to FB4 of the filter bank.

Check control voltages of the LO level control loops.

Check diagnosis voltages of the RF test points.

Check detector and control amplifier.

Perform RF level adjustment

Check detector, level D/A converter and control amplifier

Fault at RF-SWITCH1 or RF-SWITCH2, missing or faulty control voltage of tunable filters. Check the RF chain of the filter bank using network analyzer

Perform adjustment

7.3.2. Spectral Purity of Output Signal IQOUT6

Too small harmonics	Check operating point of RF amplifier in POWERUNIT, harmonics at X6, operating points of amplifiers in RF path.
Too small spurious responses at $f_{nw} = 0.5*(f_{RF} \pm 900 \text{ MHz})$	Chip of switch or switch control in POWERUNIT faulty, braided cord in upper module cover in the area of the POWERUNIT missing.
Too small spurious responses at 300 MHz from carrier	LO level of MIXER1 is faulty, bandpass filters in the IF900-path faulty
Too small spurious responses at 600 kHz from carrier	Module cover does not fit tightly, bandpass filters in the LO 1200 path faulty
Too small spurious responses at 900 MHz from carrier	LO suppression by the tracking or permanent filters of the filter bank is insufficient. Determine the faulty frequency range of the filter bank FB1 to FB4, check the tuning voltages, measure from X4 to X8 using network analyzer.

7.4. Testing and Adjustment

All measured values with no tolerance indicated are meant to be understood as reference values.

Plug the board onto the adapter included in the service kit and set up the RF connections. The adapter can then be plugged into the chassis together with the board.

Before carrying out any tests, set the instrument to a defined initial status by means of PRESET.

7.4.1. Testing the Data Transmission

The board is addressed via the serial interface. Subaddress 1 is used for the data transmission, . Subaddress 2 is used for reading and writing to the EEPROM, which contains calibration data for the filter control.

Testing: When changing between the frequencies $f_1 < 3.3 \text{ GHz}$ and $f_2 > 3.3 \text{ GHz}$, the bit SWE6-ON at D14/4 must change between low and high.

7.4.2. Testing the Reference Voltages

Test point	Nominal value/V
X20.3	10 ± 0.010
X20.2	-10 ± 0.010
X20.1	4.55 ± 0.02

7.4.3. Testing the Operating Points of the Amplifier Stages

Use a DC voltmeter to check the voltages. Measure at the collector or drain connector.

Circuit diagram sheet	Amplifier	Component No.	I _c /mA	U/V
3	RFAMP23	N38	70	4.9 ± 0.1
3	RFAMP24	N39	70	4.9 ± 0.1
4	RFAMP25	V19	58	4.4 ± 0.1
4	RFAMP26	V20	58	4.4 ± 0.1
5	RFAMP27	V87	62	4.4 ± 0.1
5	RFAMP28	V91	127	4.7 ± 0.1
5	RFAMP28	V91/UG2		$-4 \dots -0.5$
6	RFAMP29	N3	80	4.8 ± 0.1
8	RFAMP30	N4	80	4.8 ± 0.1
9	RFAMP2	N15	100	5.25 ± 0.1
10	RFAMP3	N17	75	5 ± 0.1
12	RFAMP4	N14	83	2.8 ± 0.2
12	RFAMP5	V90	140	7.1 ± 0.1
13	RFAMP6	N25	80	3.4 ± 0.2
14	RFAMP7	V92	93	7.1 ± 0.1
14	RFAMP7	V92/Gate		$-2 \dots -0.5$
17	RFAMP9	N22	80	3.4 ± 0.2
18	RFAMP10	N23	80	3.4 ± 0.2
19	RFAMP11	N18	80	3.4 ± 0.2
20	RFAMP12	N19	80	3.4 ± 0.2
21	RFAMX16.1	N20	80	3.4 ± 0.2
22	RFAMP14	N21	80	3.4 ± 0.2
23	RFAMP15	N24	80	3.4 ± 0.2
24	RFAMP16	N9	80	3.4 ± 0.2
26	RFAMP19	V94	93	7.1 ± 0.1
27	RFAMP20	V95	93	7.1 ± 0.1
28	RFAMP22	N37		3.4 ± 0.2
29	POWER UNIT V _{cc}	P11	500	7.3 ± 0.2
29	POWER UNIT V _{gg}	P12		$-5 \dots -0.5$

7.4.4. Testing the Switching Voltages of RFSWITCH 1

Use a DC voltmeter to check the voltages. (Tolerance ± 0.3 V)

	Test point	Filter OFF	FB1 on	FB2 on	FB3 on	FB4 on
SYNFIL 0	C891	4.42	4.18	-1.65	-1.65	4.55
SYNFIL 1	C753	9.80	-0.76	9.80	9.80	9.80
SYNFIL 2	C892	-10.00	-10.00	3.30	-10.00	-10.00
SYNFIL 3	C757	9.83	9.83	9.83	-3.30	9.83
SYNFIL 4	C755	-10.03	-10.03	-10.03	-10.03	6.21

7.4.5. Testing the Switching Voltages of RFSWITCH 2

Use a DC voltmeter to check the voltages. (Tolerance ± 0.3 V)

	Test point	Filter OFF	FB1 on	FB2 on	FB3 on	FB4 on
SYNFIL ON	C895	-1.67 V	-1.67 V	4.22 V	4.58 V	-1.67 V
SYNFIL 1N	C894	-9.82 V	3.34 V	-9.82 V	-9.82 V	-9.82 V
SYNFIL 2N	C899	9.97 V	9.97 V	-0.76 V	9.97 V	9.97 V
SYNFIL 3N	C898	-9.83 V	-9.83 V	-9.83 V	6.24 V	-9.83 V
SYNFIL 4N	C897	10.05 V	10.05 V	10.05 V	10.05 V	-3.32 V

7.4.6. Testing the Tuning Voltages

The diagram shows general characteristics of the tuning voltages. Individual calibration data may deviate from this curve; usually, there are deviations from the smooth tuning characteristics because of the calibration process. The upper curves show IQFILH1 and IQFILH2, the lower ones IQFILT1 and IQFILT2 (identical in this case). All 4 voltages can be read out via the diagnosis (Udiag = 20V * DACWERT/4095).

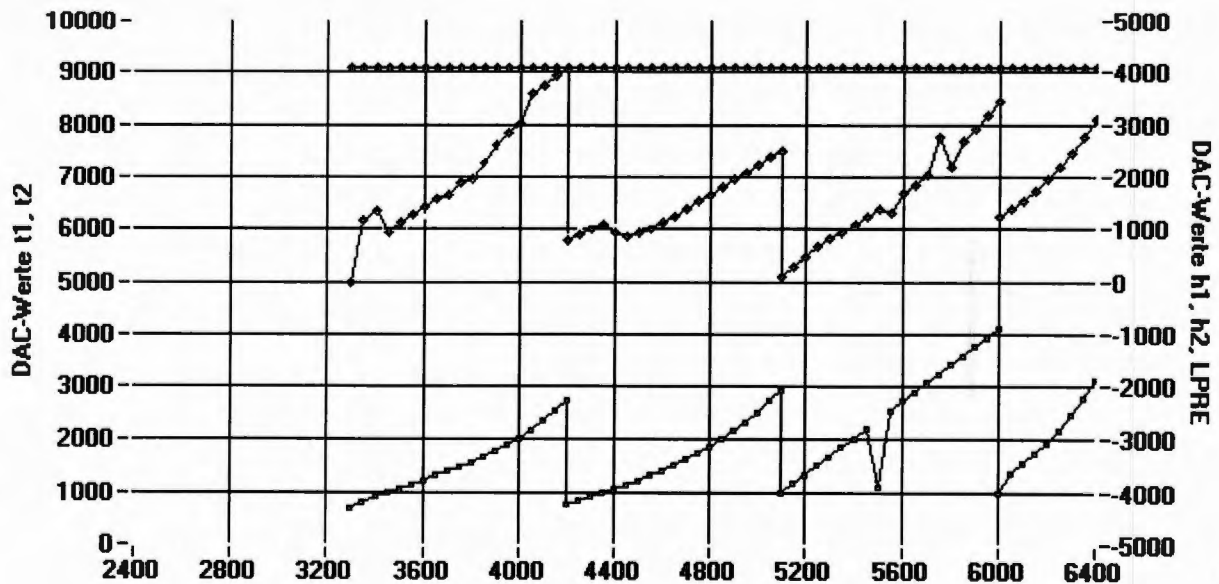

7.4.7. Testing the RF Signal Paths

The module accommodates SMP or MMCX test connectors X1 to X9. At these coaxial interfaces, matching and gain can be measured using a network analyzer, for example. For this purpose, the coupling capacitor, which is located at this place in the signal path, must be soldered from the desired input or output to the test connector. In addition to a number of coupling capacitors in the signal path, there are grounded through-connections (GND). There, it is possible, e.g. to solder in a coaxial cable and connect its inner conductors to the signal path. For specifications of nominal gain or nominal level please refer to the block diagram. S-parameter measurements in the frequency range 3 to 6 GHz require extensive equipment and knowledge. Therefore, such measurements should only be performed by trained personnel.

7.4.8. Adjusting the Drain Current of A510 in the POWER UNIT

Cut in the ammeter at X14.1 - X14.2.

Use trimmer R172 to adjust the current to 500 ± 5 mA.

7.4.9. Adjusting the Reference 10 V

Use trimmer R608 to adjust to $10 \text{ V} \pm 0.001 \text{ V}$ at the test point X20.4.

7.4.10. RF-DC-ZERO Adjustment at Output Detector

Remove jumper at X14.1-X14.2, set the voltage at X16.1 (reference X16.2) to $-17 \text{ mV} \pm 0.5 \text{ mV}$ using potentiometer R394, plug in the jumper at X14.1-X14.2.

7.4.11. Adjusting the RF Level Linearity

Instrument settings: PRESET, RF 3301 MHz, LEVEL 2.1 dBm, LEVEL/LEVEL/ATTENUATOR MODE FIXED.

Connect power sensor of power meter to RF connector of SMIQ. Save the measured value as reference value on the power meter and select the Δ dB display. Set LEVEL -18.1 dBm.

Use potentiometer R173 to adjust the DETECTOR OFFSET to 20-dB drop on the power meter.

By adjusting alternately using potentiometer R173 and potentiometer R394 (RF-DC-ZERO), the level deviation from the nominal value can be minimized in the level range -20 dBm to 13 dBm.

7.4.12. Adjusting the IF900 Level

Remove the module, unscrew the screening cover.

Unsolder the coupling capacitor C663 from the signal path and solder in such that R625 is connected to X2.

Place the module onto the service adapter, set up the RF connections, install the adapter into the instrument. Make sure to allow for sufficient cooling of the module, since the cooling effect of the screening covers and the air current is missing.

Instrument setting PRESET, RF 3301 MHz.

Connect a power meter to X2 and measure the level ($f = 900$ MHz). Adjust the RF level at X2 to -12 dBm using LEVEL IF900 (R848).

7.4.13. Calibration of the Tunable Filters

The filters are calibrated in the factory in the module pretesting. This is necessary when replacing tuning diodes in the tunable filters or the EEPROM.

7.4.14. Tables and Interfaces

7.4.14.1. Diagnosis

RF: Diagnosis voltage determined via RF rectifier.

IR: Interrupt at processor when the permissible thresholds are exceeded.

TF: Division factor (corresponds to voltage divider ratio at test point).

Diagnosis multiplexer D27:

Diag. point SMIQ	Test point	Type	IR	Umin/ Volt	Umax/ Volt	TF
10 2400	Reference 10 k Ω	DC		-10m	+10m	1
11 2401	VDETOUT Output level of module	RF		0	10	4
12 2402	UTEMP	DC		0	5	1
13 2403	Free					
14 2404	IQFILT1 tuning voltage LP tracking filter	DC		0	20	5
15 2405	IQFILT2 tuning voltage LP tracking filter	DC		0	20	5
16 2406	IQFILH1 tuning voltage HP tracking filter	DC		0	20	5
17 2407	IQFILH2 tuning voltage HP tracking filter	DC		0	20	5

Diagnosis multiplexer D25:						
Diag. point SMIQ	Test point	Type	IR	Umin/Volt	Umax/Volt	TF
20 2408	Control voltage for level preset	DC		0	10	3
21 2409	Level ahead of filter bank	RF		0		3
22 2410	Level ahead of AM Mod.	RF		0		3
23 2411	Level ahead of POWERUNIT	RF		0		3
24 2412	IF900 Level	RF		0		3
25 2413	AM control voltage	DC	IR	-15	15	3
26 2414	LO-MIXER1 control voltage	DC	IR	-15	15	3
27 2415	LO-MIXER2 control voltage	DC	IR	-15	15	3

Module temperature vs. Udiag12 (SMIQ diagnosis No. 2402):

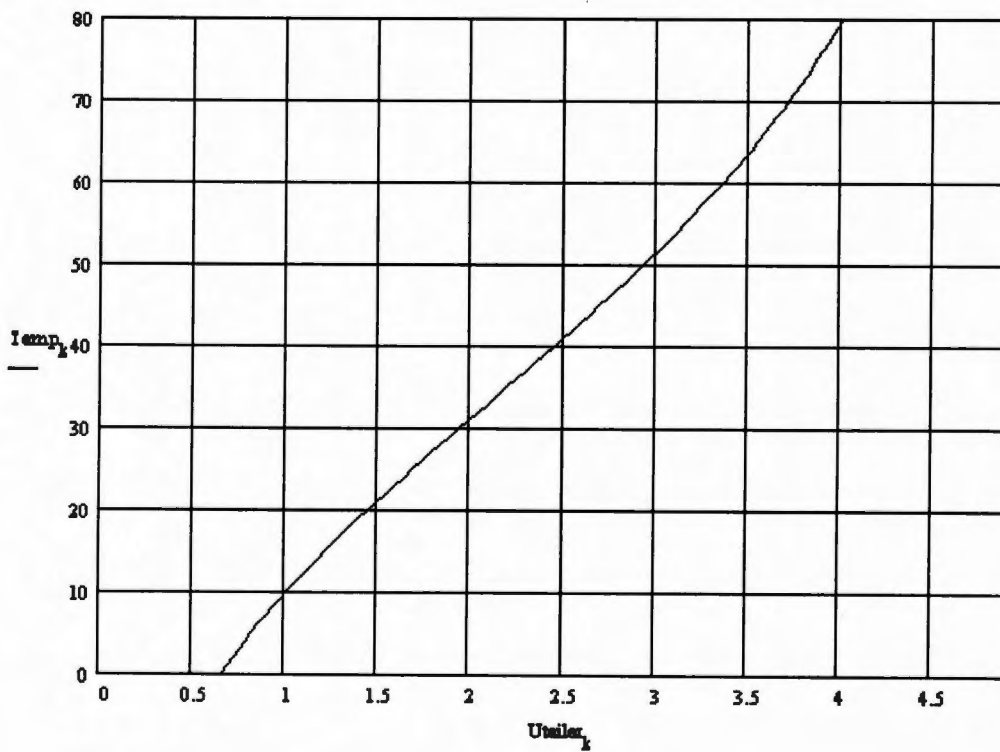

7.4.14.2. Serial Data (Subaddress 1)

Byte	Bit	Designation	Function	Control logic
11	7	free		HEX code: 0E 0D 0B 07 0F 1 1 1 0 1 1 1 0 1 1 1 0 1 1 1 0 1 1 1 1
	6	free		
	5	free		
	4	free		
	3	FILOFF4		
	2	FILOFF3		
	1	FILOFF2		
	0	FILOFF1		
10	7	IQFIL_H2	Tuning voltage	MSB
9	4	[12]	2 of highpasses	LSB
9	3	IQFIL_H1	Tuning voltage	MSB
8	0	[12]	1 of highpasses	LSB
7	7	IQFIL_T2	Tuning voltage	MSB
6	4	[12]	2 of lowpasses	LSB
6	3	IQFIL_T1	Tuning voltage	MSB
5	0	[12]	1 of lowpasses	LSB
4	7	BLANK_ENA	Function of BLANK line	1 active 0 deactivated
	6	BLANK_INV	Polarity of BLANK line	1 Blanking with BLANK = 0 0 Blanking with BLANK = 1
	5	DETOUT_ON	Switch for detector output	Detector connected to controller as actual value (ALC ON) 0 ALC OFF
	4	AM_SLOW	Switchover of ALC control bandwidth	1 ALC control bandwidth slow 0 ALC control bandwidth normal
	3	ALC_ON	Switchover between CW and IQ mode/ level control from table	1 ALC ON: Automatic level control on. 0 ALC OFF: Automatic level control off.
	2	AM_E6	Level reference voltage	1 AM signal from motherboard 0 6-V reference for RF level from module E6GHz
	1	LEV_OFF	Level reduction	1 Level off 0 Level on
	0	SWE6_ON	controls signal path in POWER UNIT	1 Frequency range 3.3 to 6.4 GHz 0 Frequency range 0.3 to 3300 MHz

Byte	Bit	Designation	Function	Control logic
3	7	LEVEL [12]	Level setting	Bit 11
2	4			Bit 0
2	3	LEVEL	Level	Bit 11
1	0	PRESET [12]	Preset	Bit 0
0	7	LOSYN_OFF	Switch for LO Mixer1	1 LO off (0.3 to 3300 MHz) 0 LO on (3.3 to 6.4 GHz)
	6	LO-MIXER2 _OFF	Switch for LO Mixer2	1 LO off (0.3 to 3300 MHz) 0 LO on (3.3 to 6.4 GHz)
	5	free	Selection diagnosis multiplexer	0 DMUX1 1 DMUX2 0 off 1 0 0
	4	DMUX_2		
	3	DMUX_1		
	2	AMUX_2	Address diagnosis multiplexer	MSB Address 0 to 7 LSB
	1	AMUX_1		
	0	AMUX_0		

7.5. Disassembly and Assembly

After opening the instrument, unlocking the module and loosening the RF connections, the module can be taken out of its slot. The screening covers of the module are fastened with screws; loosen the screws of the upper cover first and tighten them last.

For mounting the POWERUNIT observe the mounting instructions (see component location plan).

7.6. External Interfaces

Signal name	from module	Signal data	Remark
IQ300	IQMOD (IQAUX)	300 MHz \pm 50 MHz for IQ modulation -9 dBm \pm 0.1 dB 50 ohms S11 < -15 dB	
REF600	Reference/ step synthesis	600 MHz 13 dBm \pm 1 dB 50 ohms S11 < -15 dB	
VREFAM	IQMOD	DC ... 100 kHz 6 VDC \pm (AM * 6 V)	Modulation signal for AM
FIQOUT	IQMOD	<u>IQ/CW 0.3 to 3300 MHz</u> -15 to +16 dBm <u>CW 2100 to 3000 MHz</u> 13 dBm 50 ohms	<u>F \leq 3300 MHz:</u> IQMOD signal is through-connected to attenuator <u>F > 3300 MHz:</u> IQMOD in CW mode
	to module		
IQ300AUX	Instrument rear	300 MHz \pm 50 MHz for IQ modulation 50 ohms S11 < -15 dB S22 < -20 dB	IQ300 through- connected, P(IQ300) \pm 0.5 dB
REF600E	IQMOD	600 MHz from REF600 through- connected 50 ohms S22 < -15 dB	REF600 through- connected, P(REF600) \pm 0.5 dB
IQOUT6	Attenuator	<u>IQ/CW 0.3 to 3300 MHz:</u> -17 to +16 dBm <u>IQ 3300 to 6400 MHz:</u> -15 to +16 dBm 50 ohms S22 < -15 dB	through-connected signal, approx. 2 dB attenuation

Für diese Unterlage behalten wir uns alle Rechte vor
For this document all rights are reserved

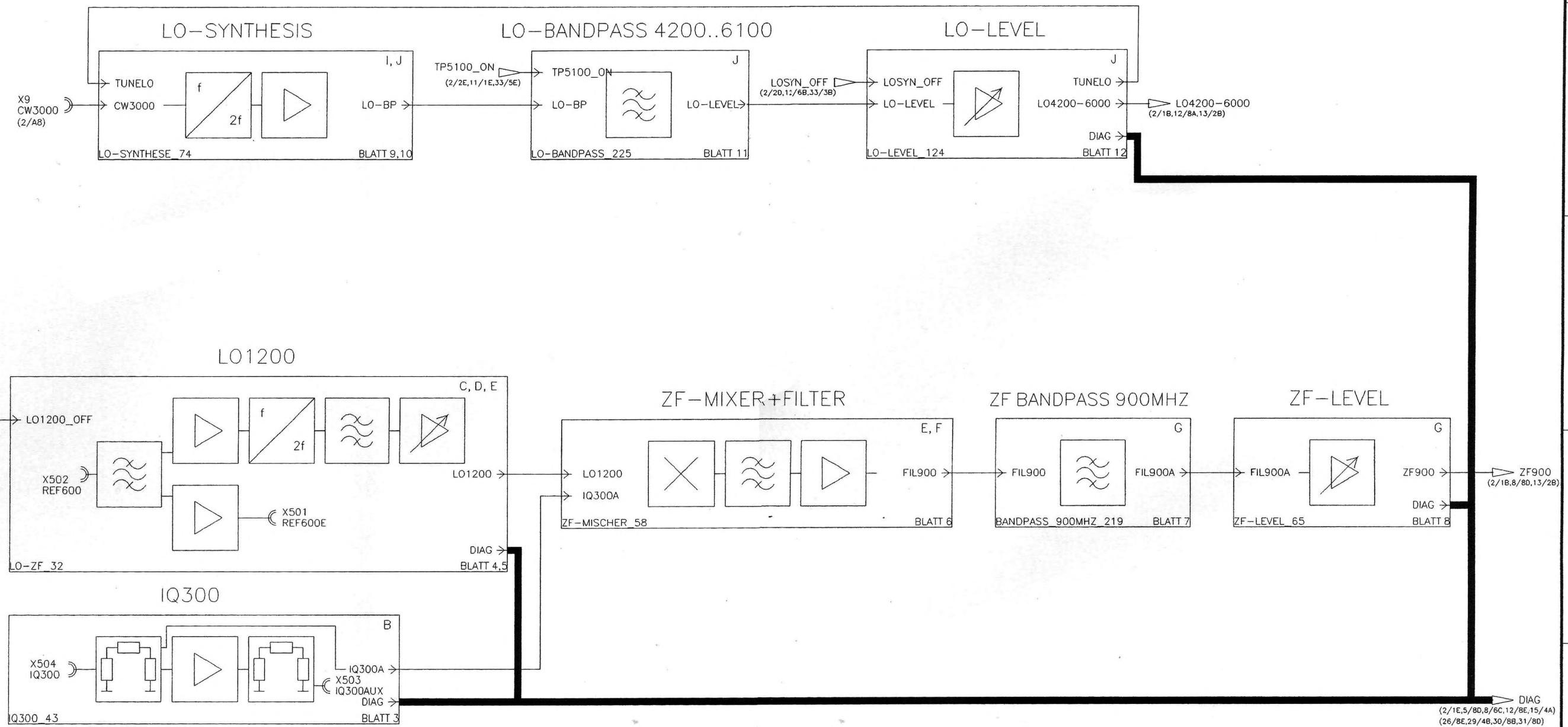

** = NOT FITTED

Bindende Angaben ueber Varianten,
Trimmwerte, Boueteile und
nicht bestueckte Boueteile siehe SA.

FOR BINDING INFORMATION ON MODELS,
TRIMMING AND COMPONENTS VALUES AND
NONFITTED COMPONENTS SEE PARTS LIST

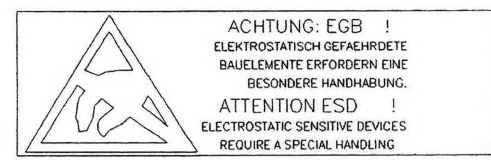

ROHDE&SCHWARZ		Benennung: 6-GHZ-ERWEITERUNG Designation: 6-GHZ-EXTENSION		Sprache / Lang.: DE	Aei / C.I.: 06.05	Blatt / Sh.: 1+
Type: SMIQ	Date: 99-09-09	Abteilung: 1GPK	Name: HOFBERGE	Zeichn. Nr.: / Drawing No.: 1084.9600.01 S		
1. Z.: used in: 1084.8004.01		TOP/TOP.1				

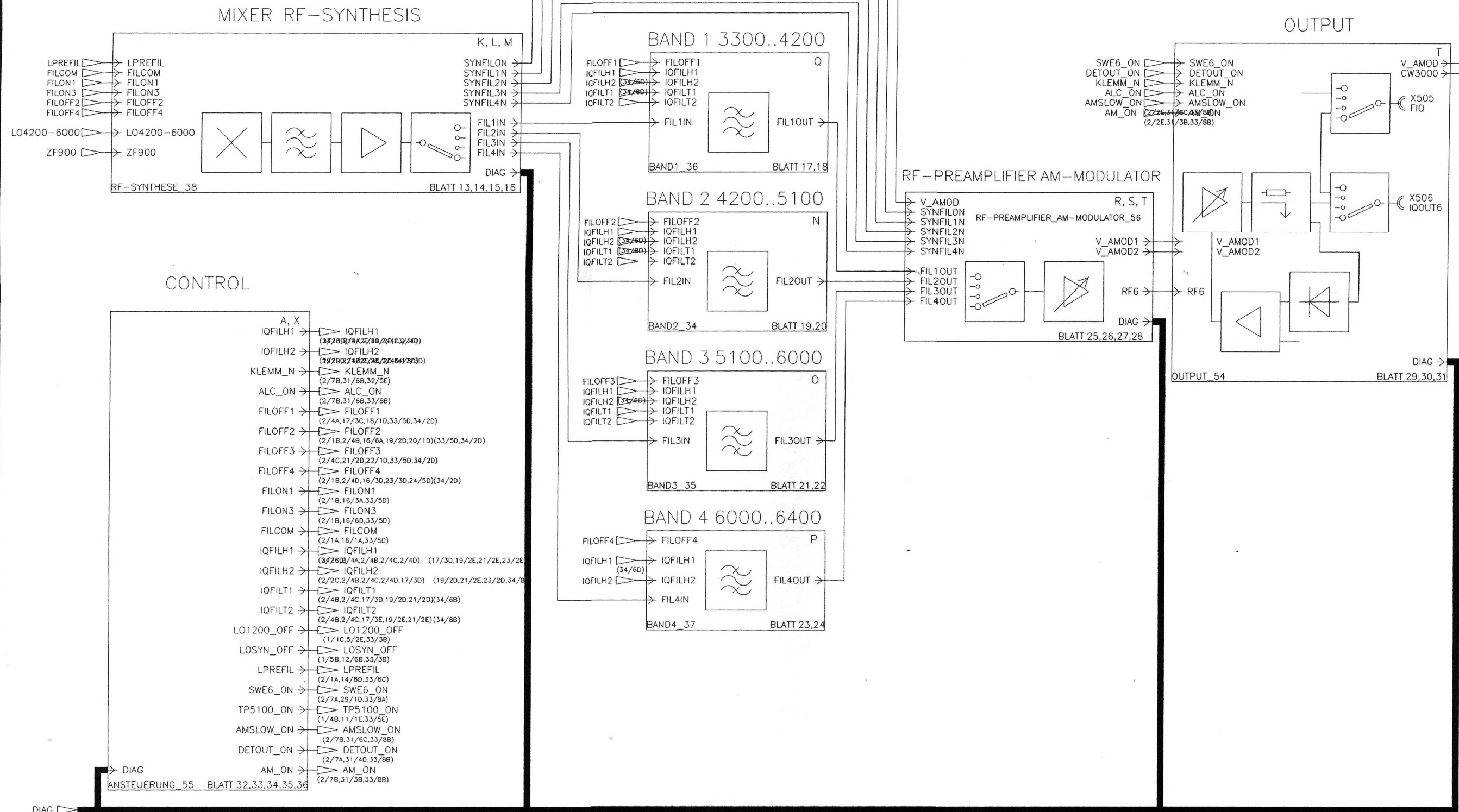

Für diese Unterlage benennen wir uns alle Rechte vor
 For this document all rights are reserved

DIAG (1/8E, 5/8E, 9/8E, 12/8E, 15/4A)
 (26/8E, 29/4B, 30/8B, 31/8D)
 (32/4D, 32/8B, 33/1D, 33/6C)

** = NCT FITTED

Bindende Angaben ueber Varianten,
 Trimmwerte, Bauteile und
 nicht bestueckte Bauteile siehe SA.
 FOR BINDING INFORMATION ON MODELS,
 TRIMMING AND COMPONENTS VALUES AND
 NONFITTED COMPONENTS SEE PARTS LIST

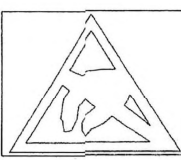

ACHTUNG: EGB !
 ELEKTROSTATISCH GEFÄHRDETE
 BAUELEMENTE ERFORDERN EINE
 BESONDERE HANDHABUNG.
ATTENTION ESD !
 ELECTROSTATIC SENSITIVE DEVICES
 REQUIRE A SPECIAL HANDLING

ROHDE&SCHWARZ		Benennung: 6-GHZ-ERWEITERUNG Designation: 6-GHZ-EXTENSION		Sprache: / Lang.: DE		Aei: / C.I.: 06.05		Blatt: / Sh.: 2+	
Type: SMIQ		Datum: 99-09-09		Abteilung: 1GPK		Name: HOFBERGE		Zeichn. Nr.: / Drawing No.: 1084.9600.01 S	
1. Z.: 1084.8004.01								TOP/TOP.2	

I bei dieser Variante sind die Rechte vorbehalten.
 For this document all rights are reserved

B

IQ300

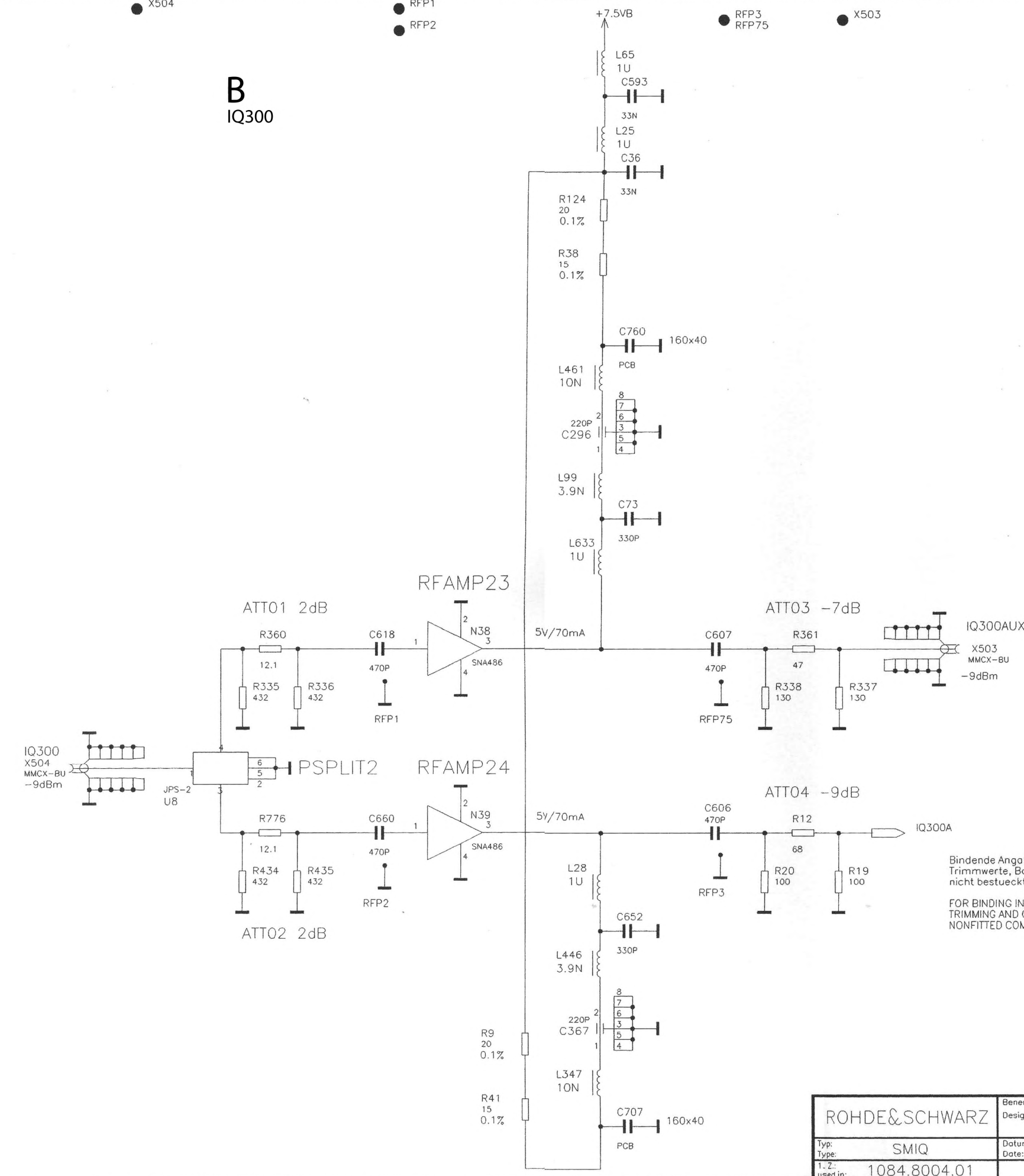

** = NOT FITTED

Bindende Angaben ueber Varianten,
 Trimmwerte, Bauteile und
 nicht bestueckte Bauteile siehe SA.
 FOR BINDING INFORMATION ON MODELS,
 TRIMMING AND COMPONENTS VALUES AND
 NONFITTED COMPONENTS SEE PARTS LIST

ACHTUNG: EGB !
 ELEKTROSTATISCH GEFÄHRDETE
 BAUELEMENTE ERFORDERN EINE
 BESONDERE HANDHABUNG.
ATTENTION ESD !
 ELECTROSTATIC SENSITIVE DEVICES
 REQUIRE A SPECIAL HANDLING

IQ300

ROHDE & SCHWARZ		Benennung: 6-GHZ-ERWEITERUNG			Sprache: / Lang.:		Aei: / C.I.:		Blatt: / Sh.:	
		Designation: 6-GHZ-EXTENSION			DE		06.05		3+	
Typ: SMIQ		Datum: 99-09-09		Abteilung: 1GPK		Name: HOFBERGE		Zeichn. Nr.: / Drawing No.:		
1-Z. used in: 1084.8004.01									1084.9600.01 S	
TOP/IQ300_43/IQ300.1										

X502

RFP4

RFP5

RFP6

RFP7

RFP8

X501

RFP9

RFP75

C

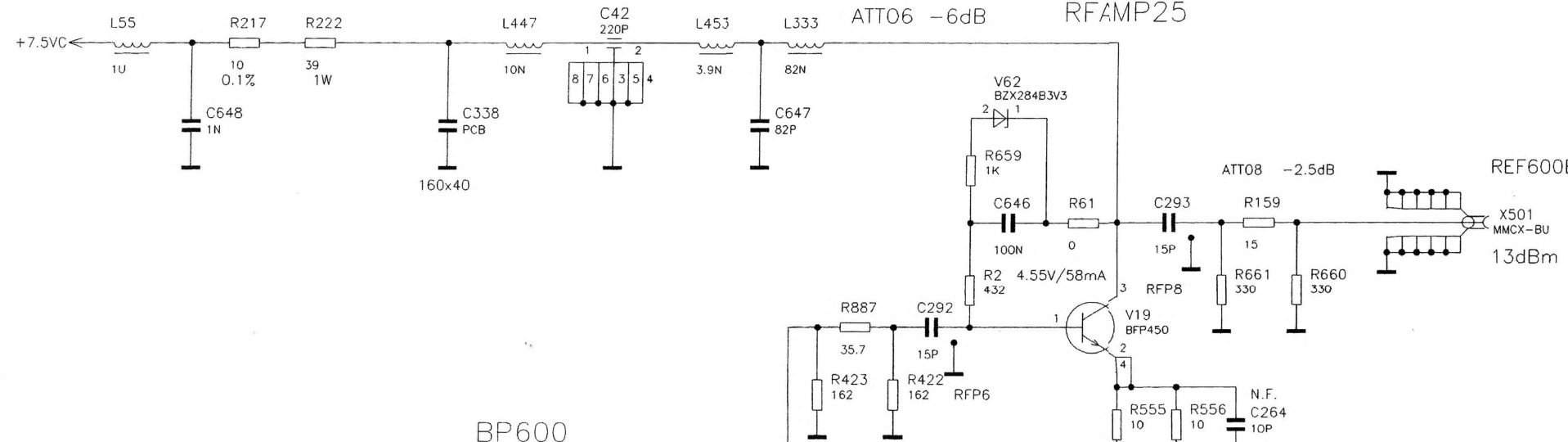

REF600E

X501
MMCX-BU
13dBm

D

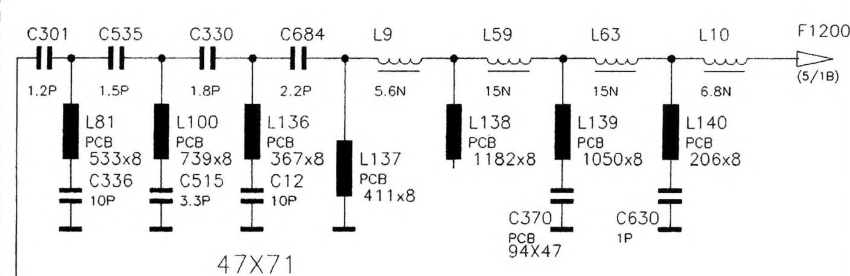

BP600

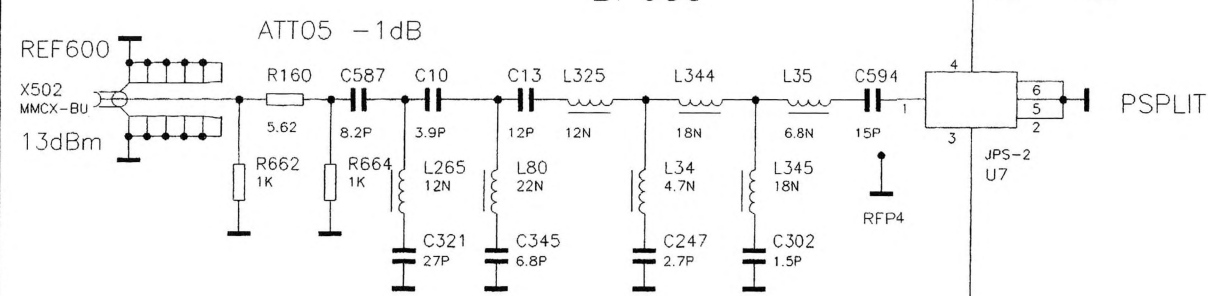

REF600
X502
MMCX-BU
13dBm

PSPLIT1

ATT07 -6dB RFAMP26 DOUBLER_2

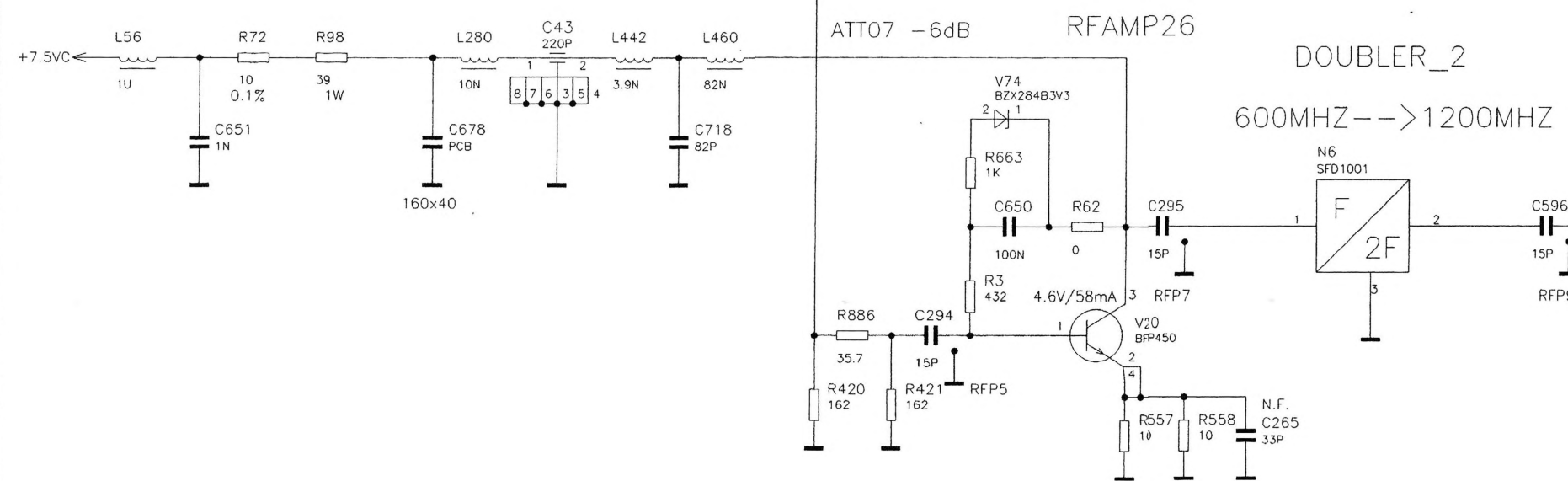

600MHZ --> 1200MHZ

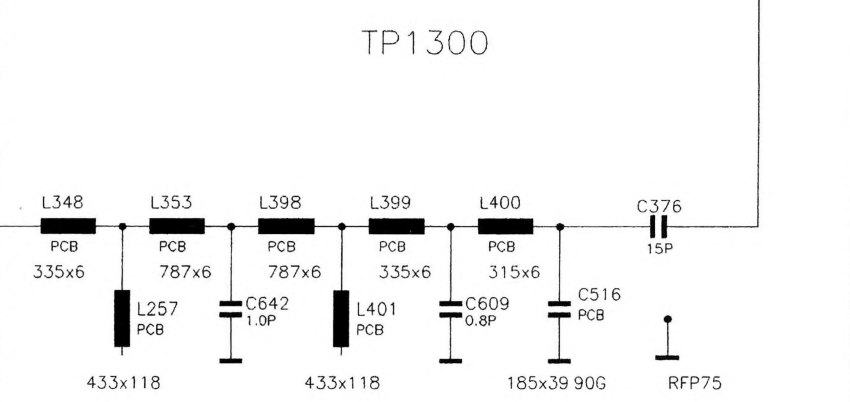

TP1300

REF600

** = NOT FITTED

Bindende Angaben ueber Varianten,
Trimmwerte, Bauteile und
nicht bestueckte Bauteile siehe SA.

FOR BINDING INFORMATION ON MODELS,
TRIMMING AND COMPONENTS VALUES AND
NONFITTED COMPONENTS SEE PARTS LIST

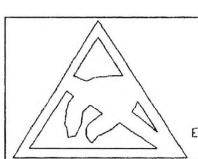

ACHTUNG: EGB !
ELEKTROSTATISCH GEFAEHRDETE
BAUELEMENTE ERFORDERNEINE
BESONDERE HANDHABUNG.

ATTENTION ESD !
ELECTROSTATIC SENSITIVE DEVICES
REQUIRE A SPECIAL HANDLING

ROHDE & SCHWARZ		Benennung: 6-GHZ-ERWEITERUNG Designation: 6-GHZ-EXTENSION		Sprache / Lang.: DE		Aei / C.I.: 06.05		Blatt / Sh.: 4+	
Typ: SMIQ		Datum: 99-09-09		Abteilung: 1GPK		Name: HOFBERGE		Zeichn. Nr.: / Drawing No.: 1084.9600.01 S	
1. Z.: used in: 1084.8004.01								TOP/LO-ZF_32/LO-ZF.1	

r uer diese Unterlage benaiten wir uns alle rechte vor
For this document all rights are reserved

E

F

RFP65

E
LO1200

RFP66

RFP67

X2

P25

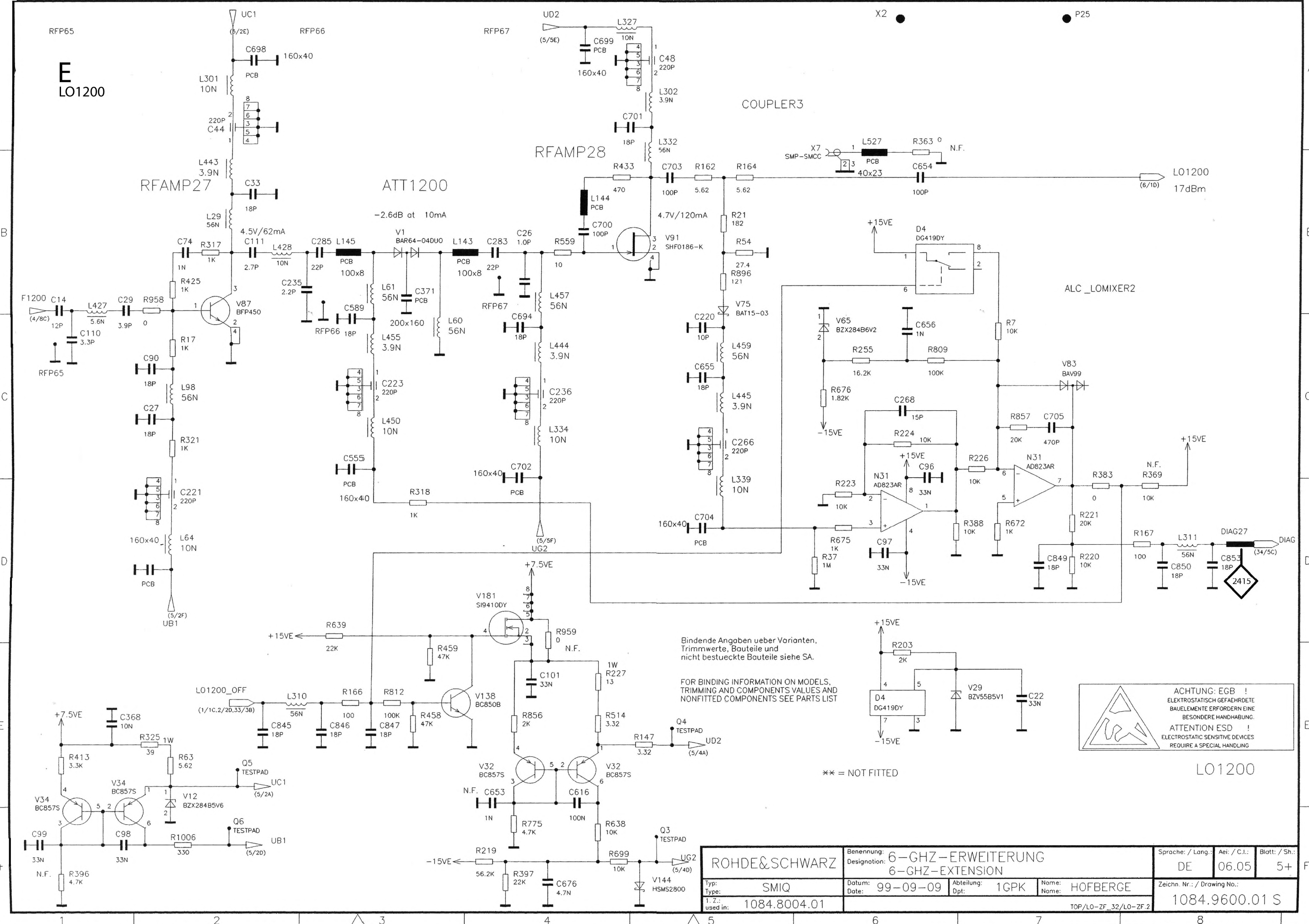

r uer diese Unterlage benannten wir uns alle rechte vor
For this document all rights are reserved

Bindende Angaben ueber Varianten,
Trimmwerte, Bauteile und
nicht bestueckte Bauteile siehe SA.

FOR BINDING INFORMATION ON MODELS,
TRIMMING AND COMPONENTS VALUES AND
NONFITTED COMPONENTS SEE PARTS LIST

** = NOT FITTED

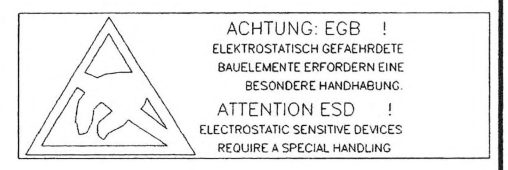

LO1200

ROHDE & SCHWARZ Benennung: 6-GHZ-ERWEITERUNG Designation: 6-GHZ-EXTENSION		Sprache / Lang.: DE Aei / C.I.: 06.05 Blatt / Sh.: 5+	
Typ: SMIQ 1. Z.: used in: 1084.8004.01		Datum: 99-09-09 Abteilung: 1GPK Name: HOFBERGE	
		Zeichn. Nr.: / Drawing No.: 1084.9600.01 S	
<small>TOP/LO-ZF_32/LO-ZF.2</small>			

1 2 3 4 5 6 7 8

RFP68

RFP69

RFP70

RFP71

E ZF-MIXER-FILTER

F1

F2

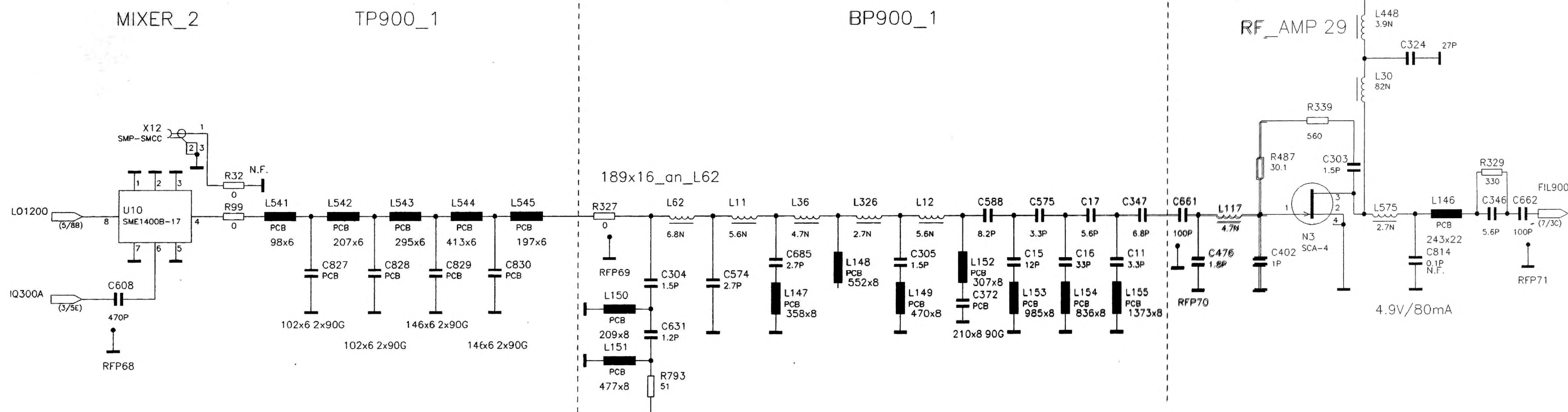

Hier diese Unterlage behalten wir uns alle Rechte vor
For this document all rights are reserved

** = NOT FITTED

Bindende Angaben ueber Varianten,
Trimmwerte, Bauteile und
nicht bestueckte Bauteile siehe SA.

FOR BINDING INFORMATION ON MODELS,
TRIMMING AND COMPONENTS VALUES AND
NONFITTED COMPONENTS SEE PARTS LIST

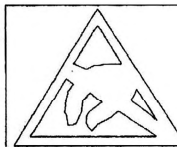

ACHTUNG: EGB !
ELEKTROSTATISCH GEFÄHRDETE
BAUELEMENTE ERFORDERN EINE
BESONDERE HANDHABUNG.

ATTENTION ESD !
ELECTROSTATIC SENSITIVE DEVICES
REQUIRE A SPECIAL HANDLING

ROHDE & SCHWARZ Typ: SMIQ 1. Z.: 1084.8004.01		Benennung: 6-GHZ-ERWEITERUNG Designation: 6-GHZ-EXTENSION! Datum: 99-09-09 Abteilungs: 1GPK Name: HOFBERGE		Sprache: / Lang.: DE Aei: / C.I.: 06.05 Blatt: / Sh.: 6+	
		Zeichn. Nr.: / Drawing No.: 1084.9600.01 S		TOP/ZF-MISCHER_58/ZF-MISCHER.1	

ZF900

G
ZF BANDPASS 900MHz

BP900_2

ATT09 -7dB

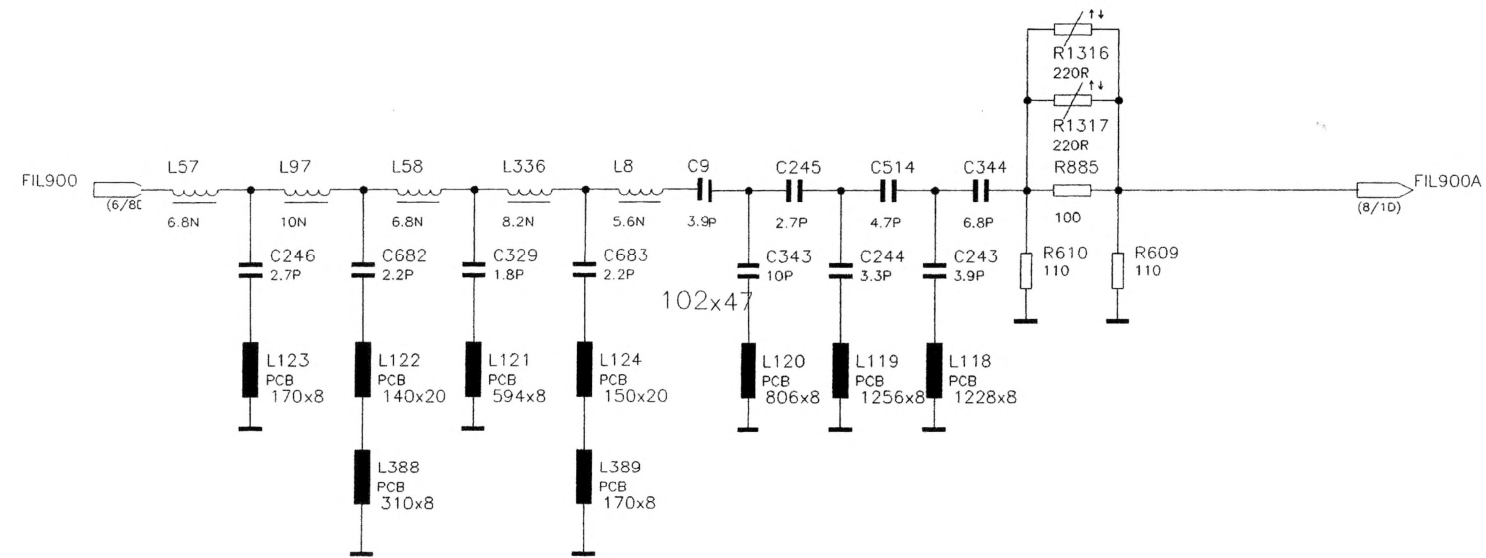

fuer diese Unterlage behalten wir uns alle Rechte vor
 For this document all rights are reserved

** = NOT FITTED

FOR BINDING INFORMATION ON MODELS,
TRIMMING AND COMPONENTS VALUES AND
NONFITTED COMPONENTS SEE PARTS LIST

FOR BINDING INFORMATION ON MODELS,
TRIMMING AND COMPONENTS VALUES AND
NONFITTED COMPONENTS SEE PARTS LIST

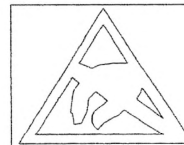

ACHTUNG: EGB !
ELEKTROSTATISCH GEFÄHRDETE
BAUELEMENTE ERFORDERN EINE
BESONDERE HANDHABUNG.
ATTENTION ESD !
ELECTROSTATIC SENSITIVE DEVICES
REQUIRE A SPECIAL HANDLING

ROHDE & SCHWARZ		Benennung: 6-GHZ-ERWEITERUNG Designation: 6-GHZ-EXTENSION		Sprache / Lang.: DE		Aei / C.I.: 06.05		Blatt / Sh.: 7+	
Typ: SMIQ		Datum: 99-09-09		Abteilung: 1GPK		Name: HOFBERGE		Zeichn. Nr.: / Drawing No.: 1084.9600.01 S	
I. Z.: used in: 1084.8004.01								TOP/BANDPASS_900MHZ_219/BANDPASS_900MHZ.1	

fuer diese Unterlage behalten wir uns alle Rechte vor
 For this document all rights are reserved

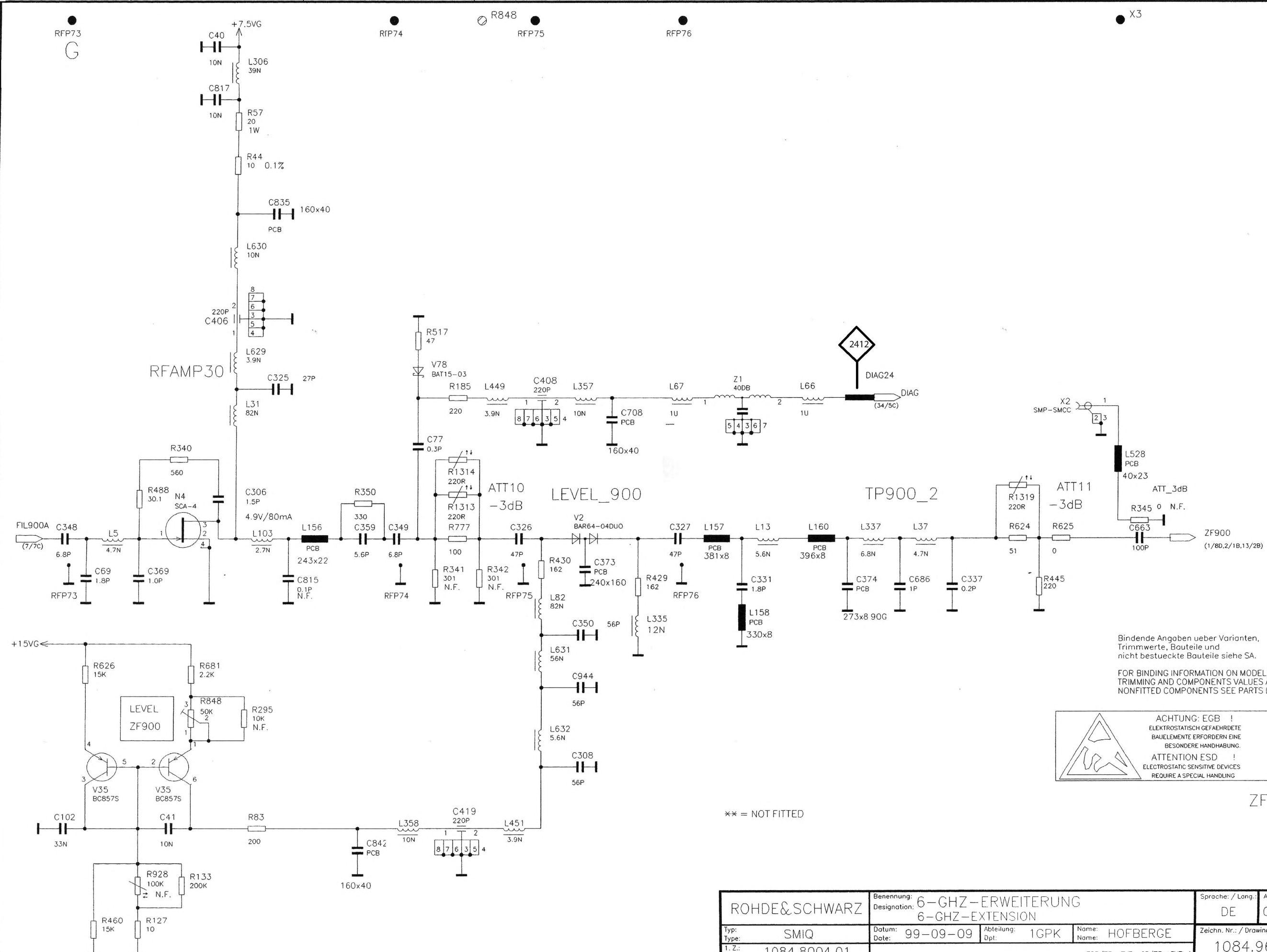

Bindende Angaben ueber Varianten,
 Trimmwerte, Bauteile und
 nicht bestueckte Bauteile siehe SA.
 FOR BINDING INFORMATION ON MODELS,
 TRIMMING AND COMPONENTS VALUES AND
 NONFITTED COMPONENTS SEE PARTS LIST

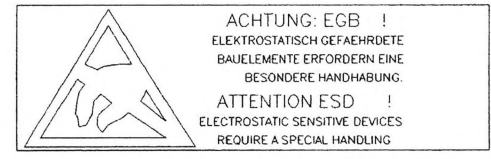

ZF900

** = NOT FITTED

ROHDE&SCHWARZ		Benennung: 6-GHZ-ERWEITERUNG Designation: 6-GHZ-EXTENSION		Sprache / Lang.: DE		Aei / C.I.: 06.05		Blatt / Sh.: 8+	
Typ: SMIQ		Datum: 99-09-09		Abteilung: 1GPK		Name: HOFBERGE		Zeichn. Nr.: / Drawing No.: 1084.9600.01 S	
1. Z.: 1084.8004.01		used in:		TOP/ZF-LEVEL_65/ZF-LEVEL.1					

1 2 3 4 5 6 7 8

LO SYNTHESIS

LO-SYNTHESIS

ruer diese Unterlage benaiten wir uns alle rechte vor
 For this document all rights are reserved

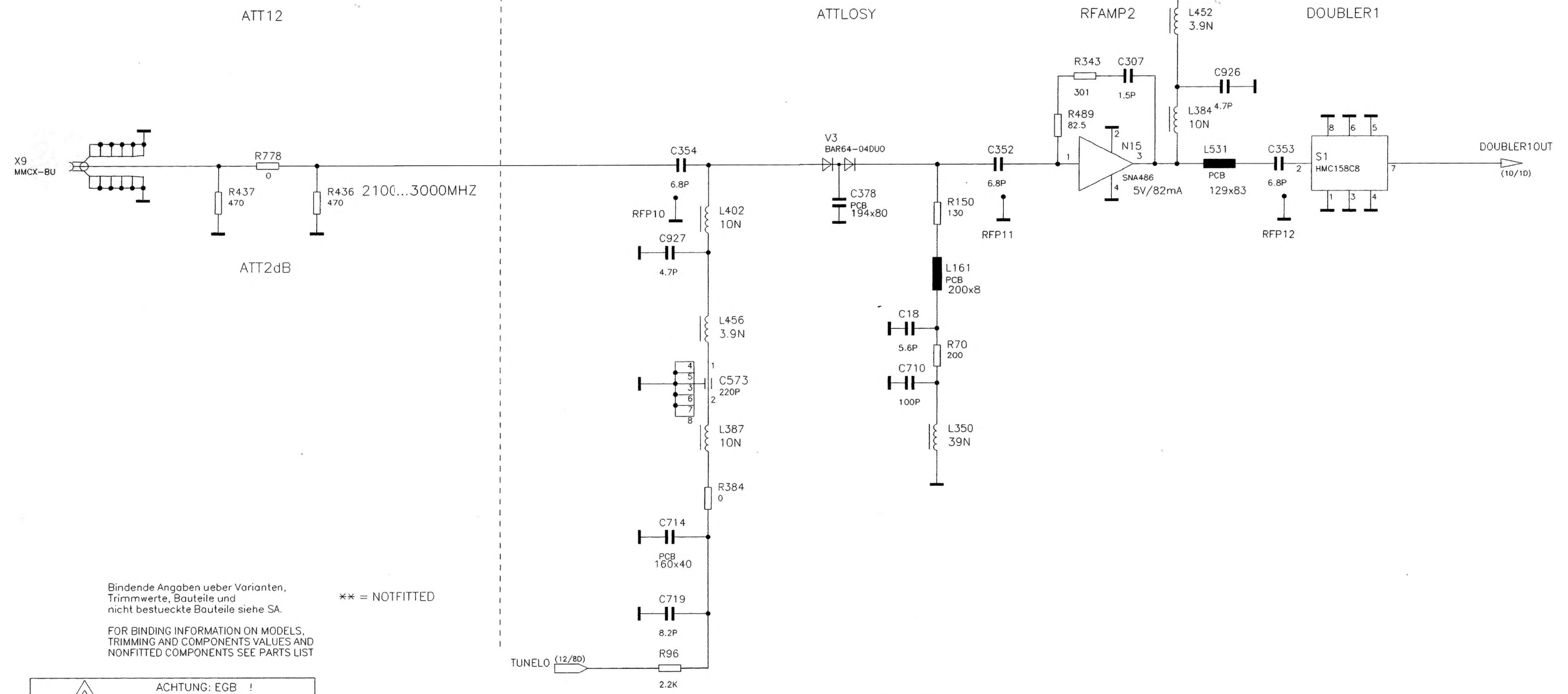

Bindende Angaben ueber Varianten,
 Trimmwerte, Bauteile und
 nicht bestueckte Bauteile siehe SA.
 ** = NOTFITTED
 FOR BINDING INFORMATION ON MODELS,
 TRIMMING AND COMPONENTS VALUES AND
 NONFITTED COMPONENTS SEE PARTS LIST

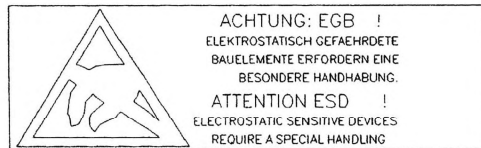

ROHDE&SCHWARZ Typ: SMIQ 1. Z.: 1084.8004.01 used in:		Benennung: 6-GHZ-ERWEITERUNG Designation: 6-GHZ-ERWEITERUNG Datum: 99-09-09 Date:		Abteilung: 1GPK Dpt: Name: HOFBERGE Name:		Sprache: / Lang.: DE Aei: / C.I.: 06.05 Blatt: / Sh.: 9+ Zeichn. Nr.: / Drawing No.: 1084.9600.01 S	
TOP/LO-SYNTHESE_74/LO-SYNTHESE.1							

ruer diese Unterlage behalten wir uns alle Rechte vor
 For this document all rights are reserved

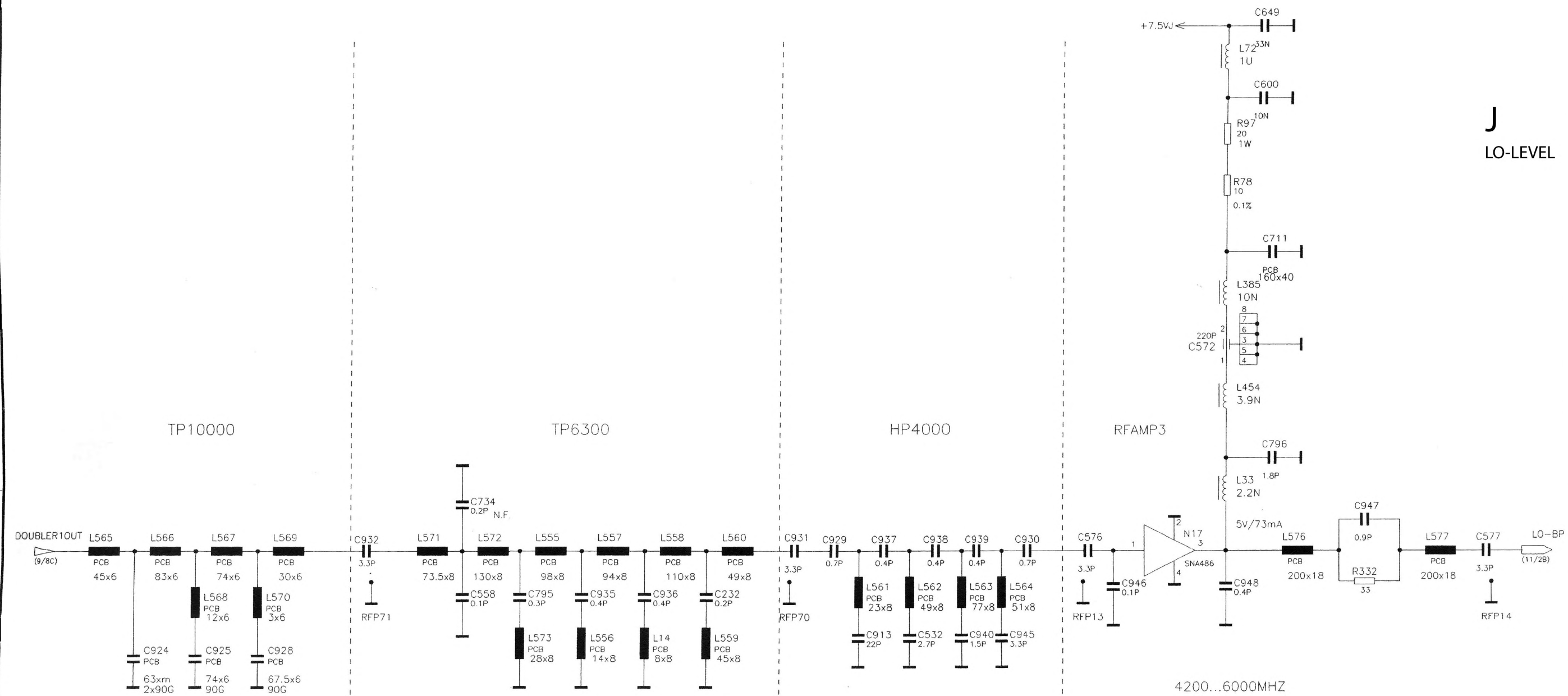

J
LO-LEVEL

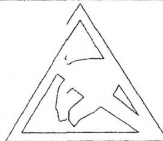

 ACHTUNG: EGB !
 ELEKTROSTATISCH GEFÄHRDETE
 BAUELEMENTE ERFORDERN EINE
 BESONDERE HANDHABUNG.
 ATTENTION ESD !
 ELECTROSTATIC SENSITIVE DEVICES
 REQUIRE A SPECIAL HANDLING

ROHDE&SCHWARZ Typ: SMIQ 1. Z.: 1084.8004.01		Benennung: 6-GHZ-ERWEITERUNG Designation: 6-GHZ-EXTENSION Datum: 99-09-09 Name: HOFBERGE		Sprache: / Lang.: DE Aei: / Cl.: 06.05 Blatt: / Sh.: 10+	
		Abteilung: 1GPK Dpt:		Zeichn. Nr.: / Drawing No.: 1084.9600.01 S	
TOP/LO-SYNTHESE_74/LO-SYNTHESE.2					

RFP72

RFP73

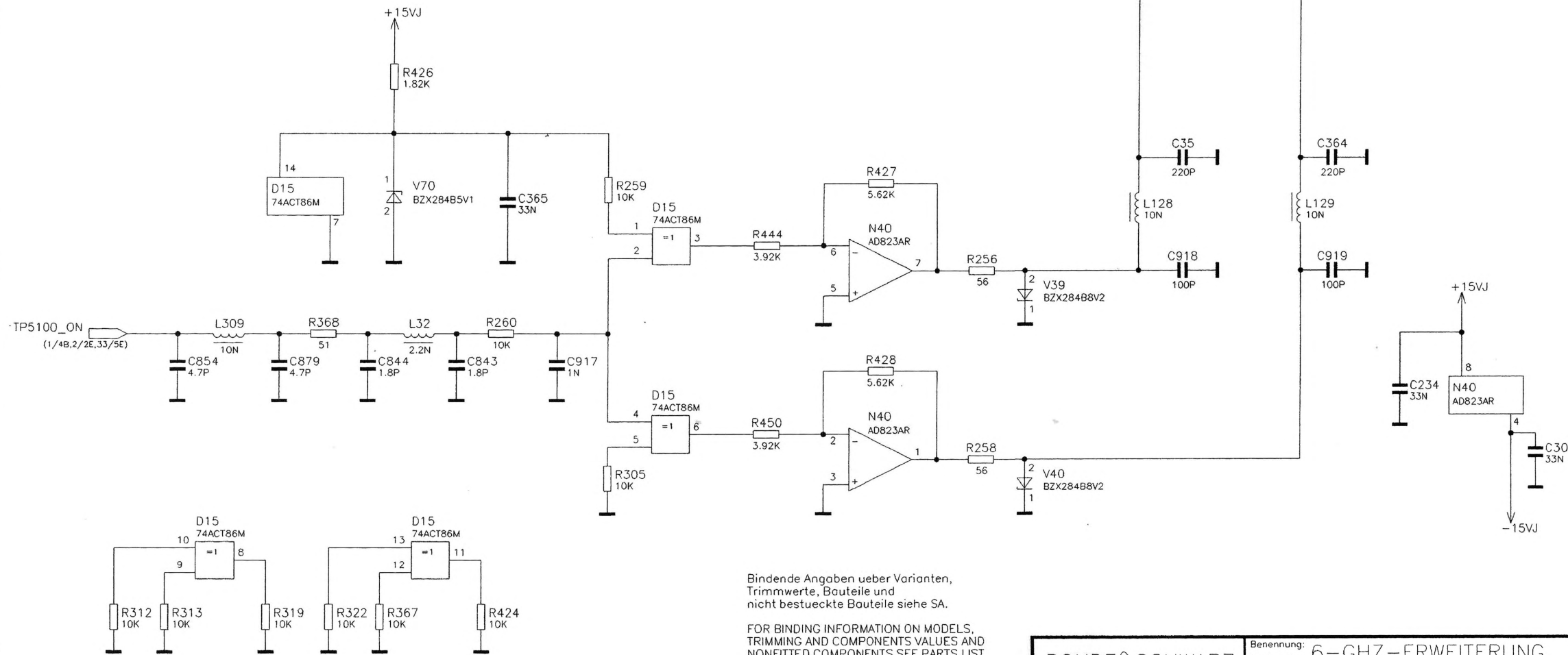
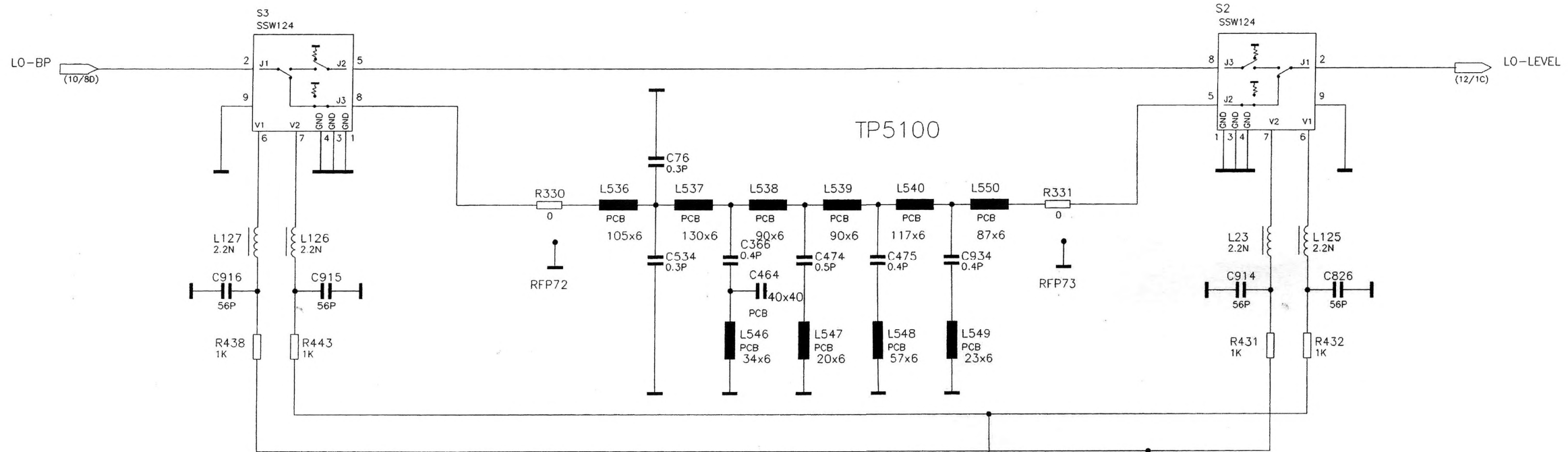
J



ACHTUNG: EGB !
ELEKTROSTATISCH GEFÄHRDETE
BAUELEMENTE ERFORDERN EINE
BESONDERE HANDHABUNG.
ATTENTION ESD !
ELECTROSTATIC SENSITIVE DEVICES
REQUIRE A SPECIAL HANDLING

Bindende Angaben ueber Varianten,
Trimmwerte, Bauteile und
nicht bestueckte Bauteile siehe SA.
FOR BINDING INFORMATION ON MODELS,
TRIMMING AND COMPONENTS VALUES AND
NONFITTED COMPONENTS SEE PARTS LIST

** = NOT FITTED

ROHDE & SCHWARZ		Benennung: 6-GHZ-ERWEITERUNG 6-GHZ-EXTENSION		Sprache: / Lang.: DE		Aei. / C.I.: 06.05		Blatt. / Sh.: 11+	
Typ: SMIQ		Datum: 99-09-09		Abteilung: 1GPK		Name: HOFBERGE		Zeichn. Nr.: / Drawing No.: 1084.9600.01 S	
1. Z.: 1084.8004.01								TOP/LO-BANDPASS_225/LO-BANDPASS.1	

rueber diese urterfertige benaiten wir uns alle rechte vor
For this document all rights are reserved

(E)

ruer diese Unterlage benaiten wir uns alle rechte vor
 For this document all rights are reserved

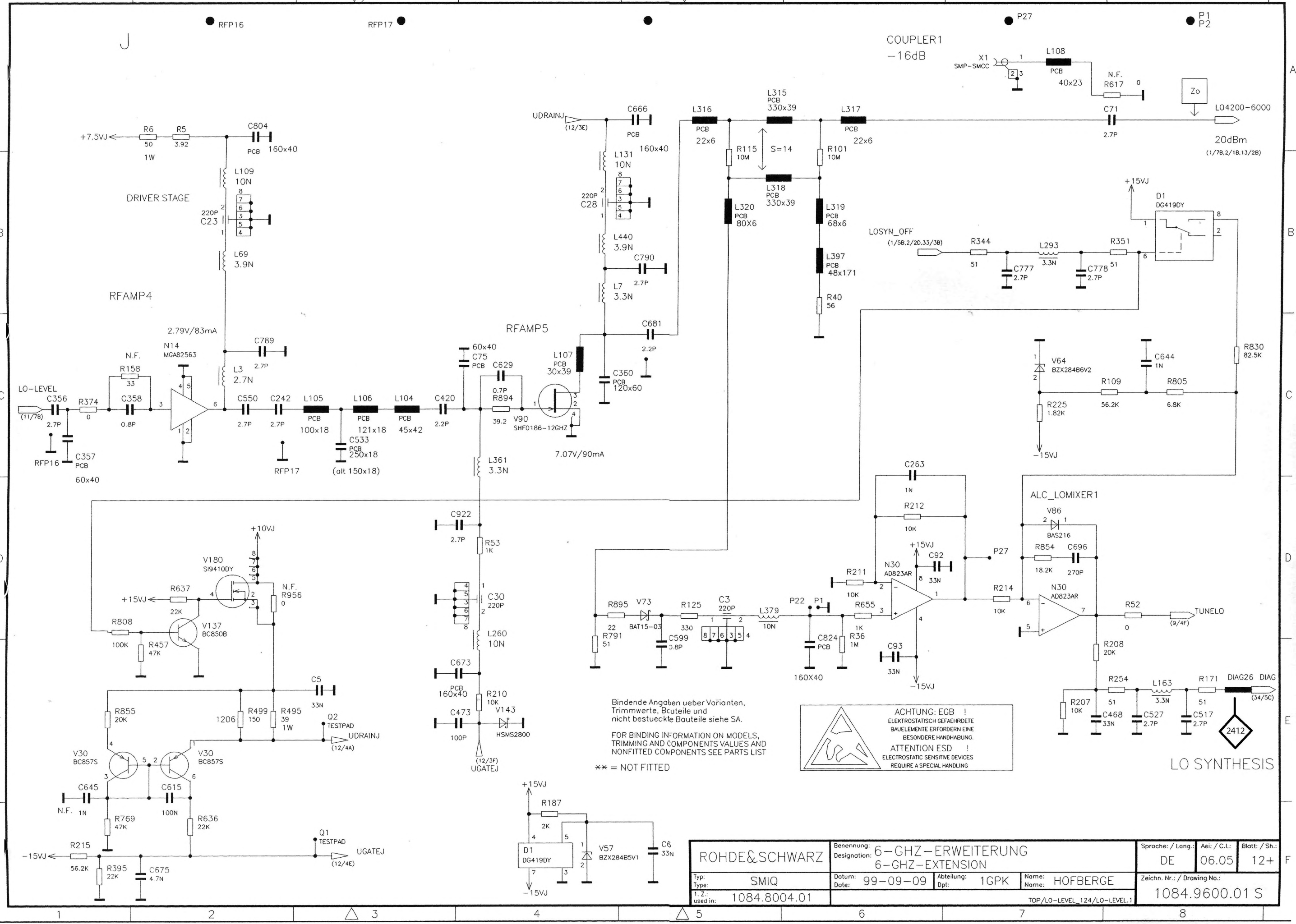

Bindende Angaben ueber Varianten,
 Trimmwerte, Bcuteile und
 nicht bestueckte Bauteile siehe SA.
 FOR BINDING INFORMATION ON MODELS,
 TRIMMING AND COMPONENTS VALUES AND
 NONFITTED COMPONENTS SEE PARTS LIST
 ** = NOT FITTED

ACHTUNG: EGB !
 ELEKTROSTATISCH GEFAEHRDENE
 BAUELEMENTE ERFOEDERN EINE
 BESONDERE HANDHABUNG.
ATTENTION ESD !
 ELECTROSTATIC SENSITIVE DEVICES
 REQUIRE A SPECIAL HANDLING

ROHDE&SCHWARZ		Benennung: 6-GHZ-ERWEITERUNG Designation: 6-GHZ-EXTENSION		Sprache: / Lang.: DE		Aei: / C.I.: 06.05		Blatt: / Sh.: 12+	
Typ: SMIQ		Datum: 99-09-09		Abteilung: 1GPK		Name: HOFBERGE		Zeichn. Nr.: / Drawing No.: 1084.9600.01 S	
I. Z.: used in: 1084.8004.01								TOP/LO-LEVEL_124/LO-LEVEL.1	

2412
 LO SYNTHESIS

H

RFP16

RFP80

RFP17

K

MIXER1

TP10000

HP3000

SYNTHESIS FILTER_HP

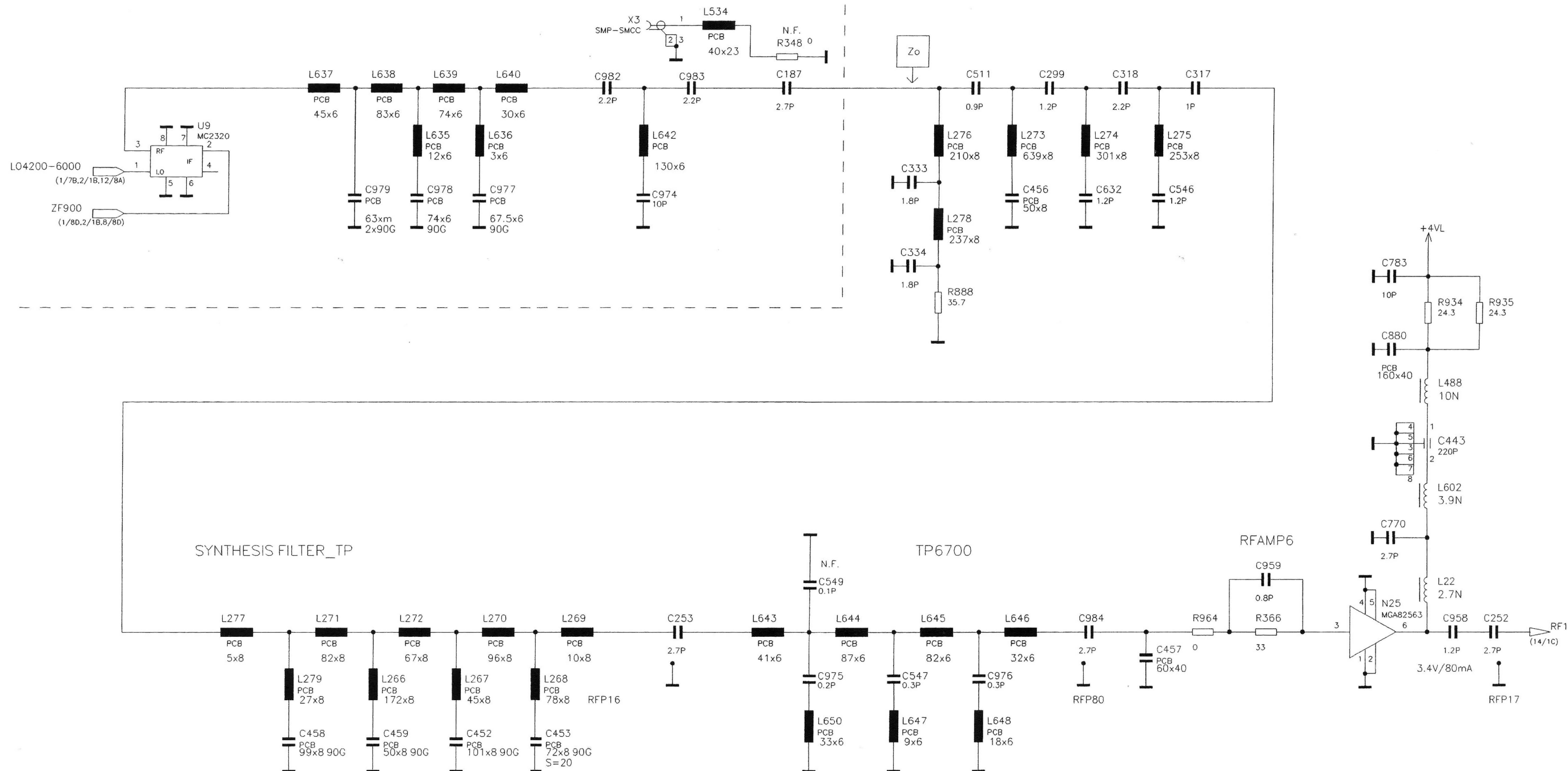

r uer diese unterlage behalten wir uns alle rechte vor
For this document all rights are reserved

Bindende Angaben ueber Varianten,
Trimmwerte, Bauteile und
nicht bestueckte Bauteile siehe SA.

** = NOT FITTED

FOR BINDING INFORMATION ON MODELS,
TRIMMING AND COMPONENTS VALUES AND
NONFITTED COMPONENTS SEE PARTS LIST

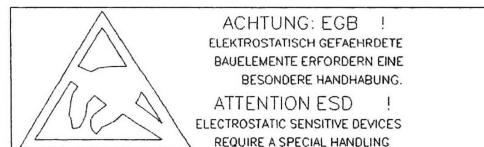

ROHDE&SCHWARZ		Benennung: 6-GHZ-ERWEITERUNG Designation: 6-GHZ-EXTENSION		Sprache / Lang.: DE		Aei / C.I.: 06.05		Blatt / Sh.: 13+	
Typ: SMIQ		Datum: 99-09-09		Abteilung: 1GPK		Name: HOFBERGE		Zeichn. Nr.: / Drawing No.: 1084.9600.01 S	
I. Z.: 1084.8004.01								TOP/RF-SYNTHESE_38/RF-SYNTHESE.1	

1 2 3 4 5 6 7 8

RF SYNTHESIS

fuer diese Unterlage behalten wir uns alle Rechte vor
 For this document all rights are reserved

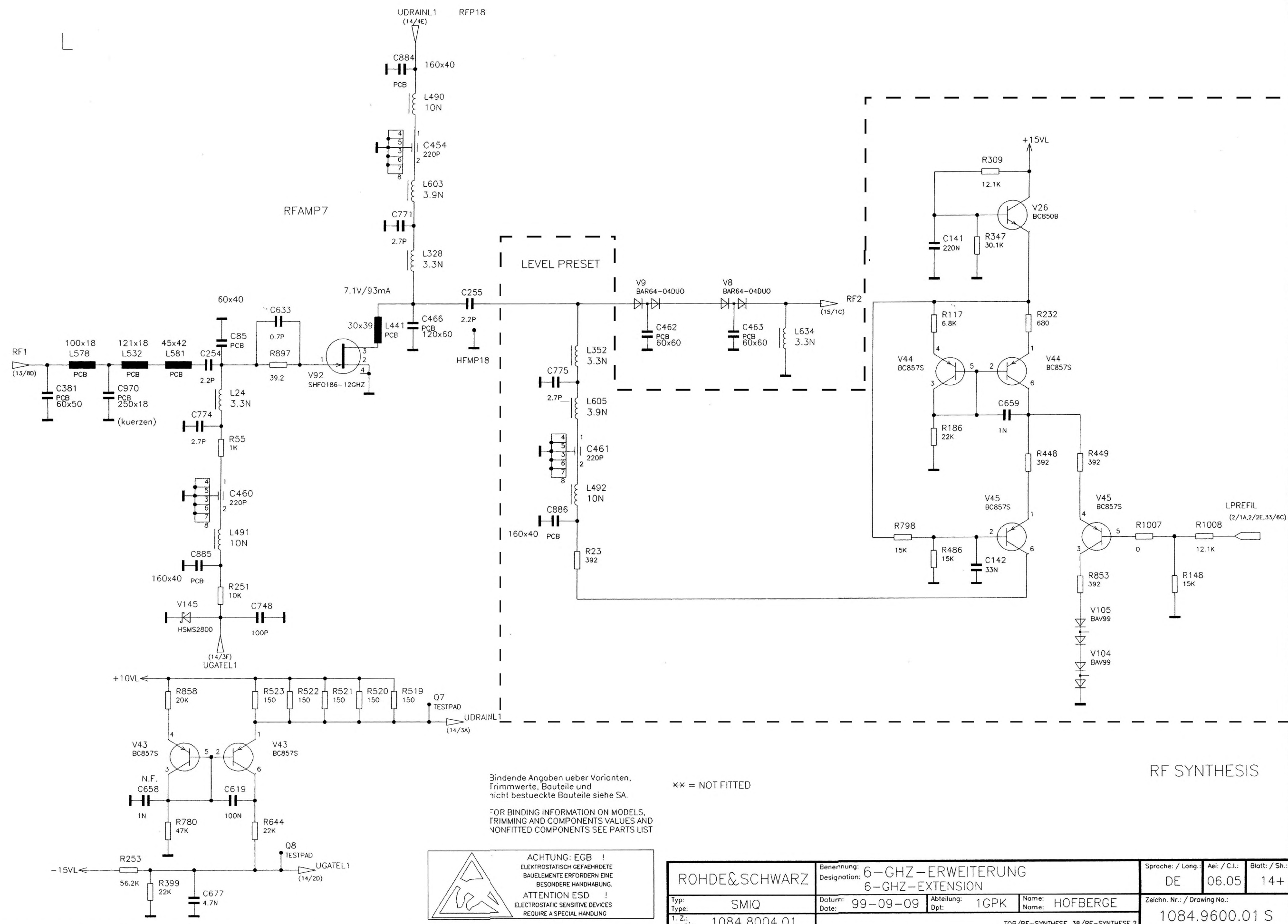

Bindende Angaben ueber Varianten,
 Trimmwerte, Bauteile und
 nicht bestueckte Bauteile siehe SA.

FOR BINDING INFORMATION ON MODELS,
 TRIMMING AND COMPONENTS VALUES AND
 NONFITTED COMPONENTS SEE PARTS LIST

ACHTUNG: EGB !
 ELEKTROSTATISCH GEFAEHRDETE
 BAUELEMENTE ERFORDERN EINE
 BESONDERE HANDHABUNG.
ATTENTION ESD !
 ELECTROSTATIC SENSITIVE DEVICES
 REQUIRE A SPECIAL HANDLING

ROHDE&SCHWARZ Typ: SMIQ 1. Z.: 1084.8004.01		Benennung: 6-GHZ-ERWEITERUNG Designation: 6-GHZ-EXTENSION		Sprache: / Lang.: DE Aei: / C.I.: 06.05 Blatt: / Sh.: 14+	
		Datum: 99-09-09 Date:		Abteilung: 1GPK Dpt:	
		Name: HOFBERGE Name:		Zeichn. Nr.: / Drawing No.: 1084.9600.01 S	
TOP/RF-SYNTHESE_38/RF-SYNTHESE.2					

RF SYNTHESIS

** = NOT FITTED

RFP18

RF SYNTHESIS

X4

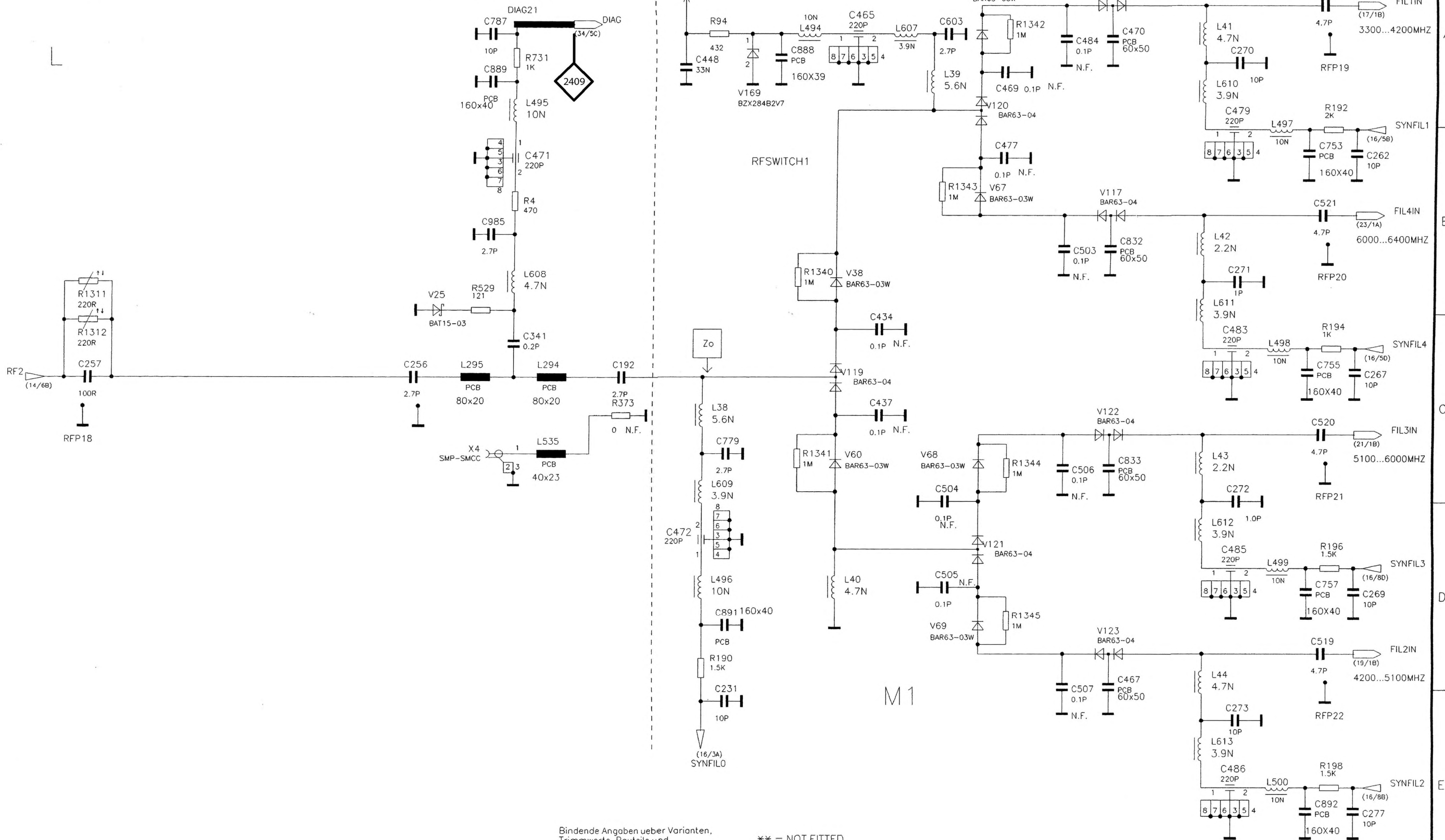

Bindende Angaben ueber Varianten,
Trimmwerte, Bauteile und
nicht bestueckte Bauteile siehe SA.

** = NOT FITTED

FOR BINDING INFORMATION ON MODELS,
TRIMMING AND COMPONENTS VALUES AND
NONFITTED COMPONENTS SEE PARTS LIST



ACHTUNG: EGB !
ELEKTROSTATISCH GEFÄHRDETE
BAUELEMENTE ERFORDERN EINE
BESONDERE HANDHABUNG.
ATTENTION ESD !
ELECTROSTATIC SENSITIVE DEVICES
REQUIRE A SPECIAL HANDLING

ROHDE & SCHWARZ		Benennung: 6-GHZ-ERWEITERUNG Designation: 6-GHZ-EXTENSION		Sprache: / Lang.: DE		Aei: / C.I.: 06.05		Blatt: / Sh.: 15+	
Typ: SMIQ		Datum: 99-09-09		Abteilung: 1GPK		Name: HOFBERGE		Zeichn. Nr.: / Drawing No.: 1084.9600.01 S	
I. Z.: used in: 1084.8004.01								TOP/RF--SYNTHESE_38/RF--SYNTHESE.3	

r uer diese Unterlage benaiten wir uns alle Rechte vor
 For this document all rights are reserved

M

RF SYNTHESIS

SWITCH DRIVER

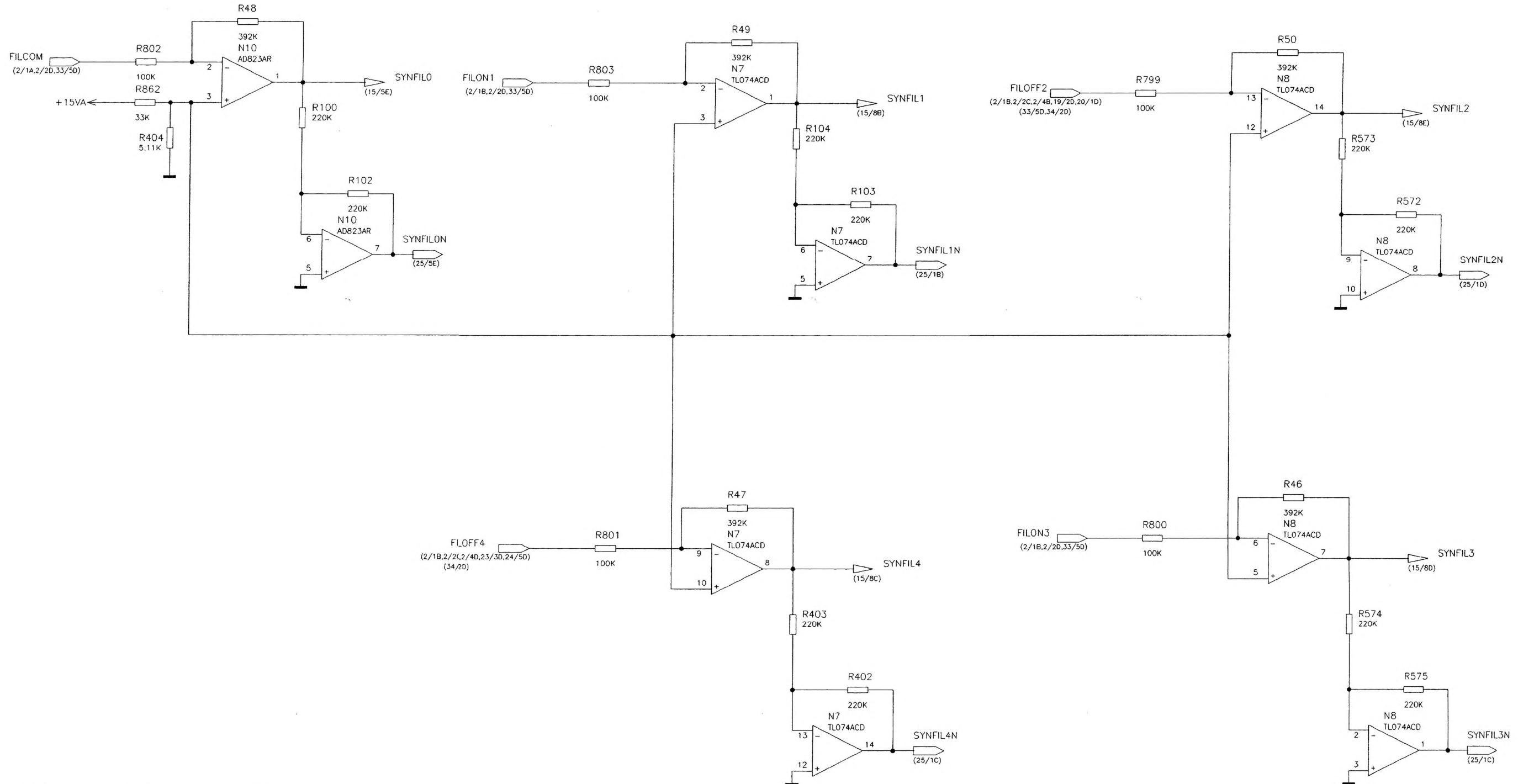

Für diese Unterlage behalten wir uns alle Rechte vor
For this document all rights are reserved

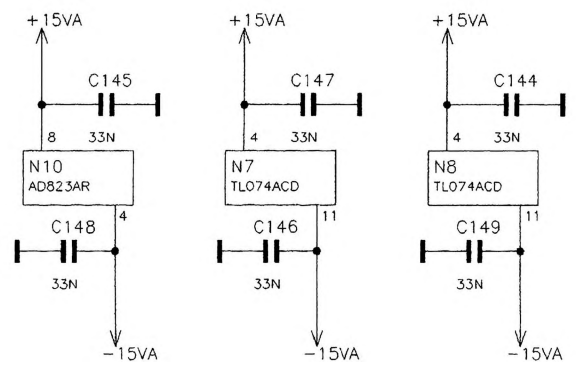

Bindende Angaben ueber Varianten, Trimmwerte, Bauteile und nicht bestueckte Bauteile siehe SA. ** = NOT FITTED

FOR BINDING INFORMATION ON MODELS, TRIMMING AND COMPONENTS VALUES AND NONFITTED COMPONENTS SEE PARTS LIST

ACHTUNG: EGB !
ELEKTROSTATISCH GEFÄHRDETE BAUELEMENTE ERFORDERN EINE BESONDERE HANDHABUNG.
ATTENTION ESD !
ELECTROSTATIC SENSITIVE DEVICES REQUIRE A SPECIAL HANDLING

Benennung: 6-GHZ-ERWEITERUNG Designation: 6-GHZ-EXTENSION		Sprache: / Lang.: DE	Aei: / C.I.: 06.05	Blott: / Sh.: 16+
Typ: SMIQ	Datum: 99-09-09	Abteilung: 1GPK	Name: HOFBERGE	Zeichn. Nr.: / Drawing No.: 1084.9600.01 S
1. Z.: used in: 1084.8004.01	TOP/RF-SYNTHESE_38/RF-SYNTHESE.4			

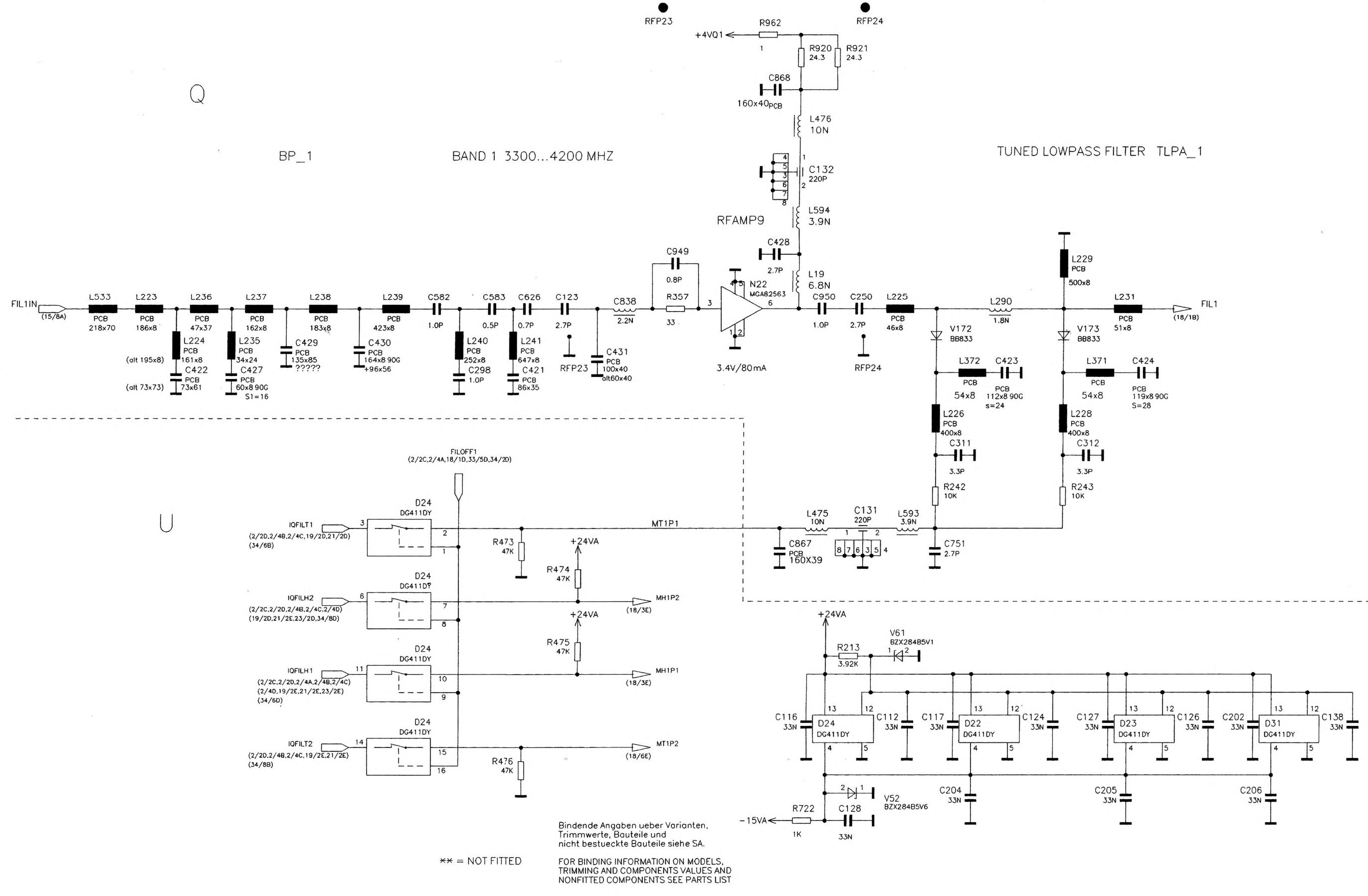

ruer diese Unterlage benaiten wir uns alle Rechte vor
 For this document all rights are reserved

U

Bindende Angaben ueber Varianten,
 Trimmwerte, Bauteile und
 nicht bestueckte Bauteile siehe SA.
 ** = NOT FITTED
 FOR BINDING INFORMATION ON MODELS,
 TRIMMING AND COMPONENTS VALUES AND
 NONFITTED COMPONENTS SEE PARTS LIST

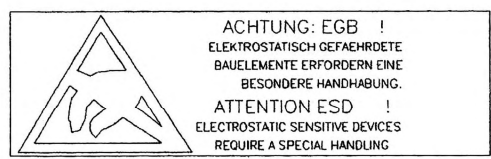

ROHDE&SCHWARZ Typ: SMIQ 1. Z.: 1084.8004.01		Benennung: 6-GHZ-ERWEITERUNG Designation: 6-GHZ-EXTENSION Datum: 99-09-09 Dept: 1GPK		Name: HOFBERGE Sprache: / Lang.: DE Aei: / C.I.: 06.05 Blatt: / Sh.: 17+	
Zeichn. Nr.: / Drawing No.: 1084.9600.01 S			TOP/BAND1_36/BAND1.1		

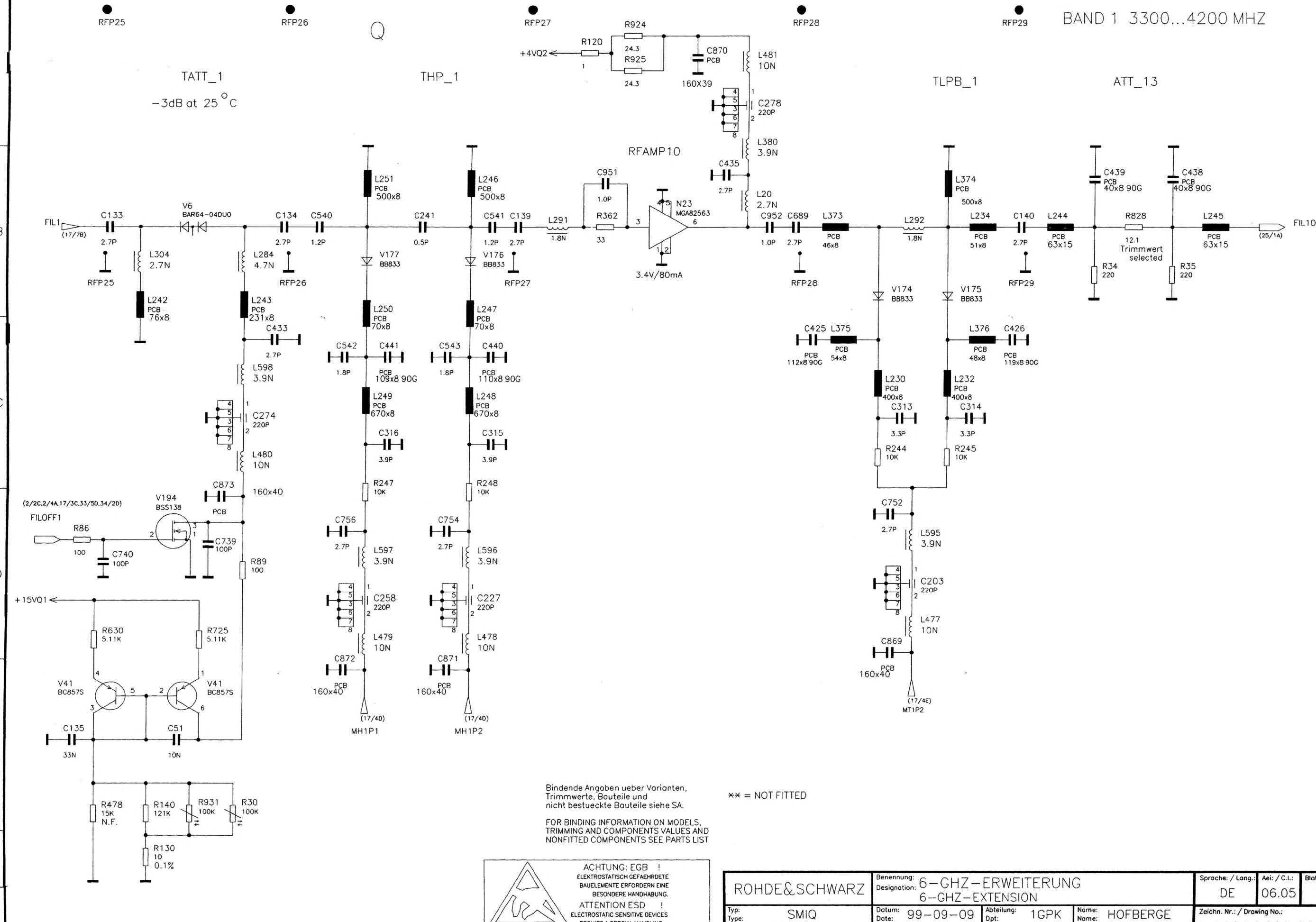

r uer diese Unterlage benaiten wir uns alle Rechte vor
 For this document all rights are reserved

Bindende Angaben ueber Varianten,
 Trimmwerte, Bauteile und
 nicht bestueckte Bauteile siehe SA.
 FOR BINDING INFORMATION ON MODELS,
 TRIMMING AND COMPONENTS VALUES AND
 NONFITTED COMPONENTS SEE PARTS LIST

** = NOT FITTED

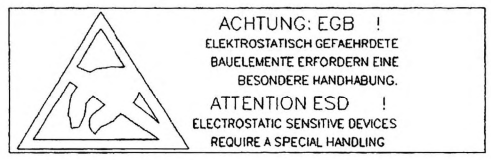

ROHDE & SCHWARZ		Benennung: 6-GHZ-ERWEITERUNG Designation: 6-GHZ-EXTENSION		Sprache: / Lang.: DE Aei: / C.I.: 06.05 Blatt: / Sh.: 18+	
Typ: SMIQ		Datum: 99-09-09		Abteilung: 1GPK Name: HOFBERGE	
I. Z.: 1084.8004.01		Date:		Zeichn. Nr.: / Drawing No.: 1084.9600.01 S	
TOP/BAND1_36/BAND1.2					

BAND 2 4200...5100 MHZ

N

RFP87

RFP30

RFP31

TP5100

HP4000

RFAMP11

TLPA_2

TUNED LOWPASS FILTER

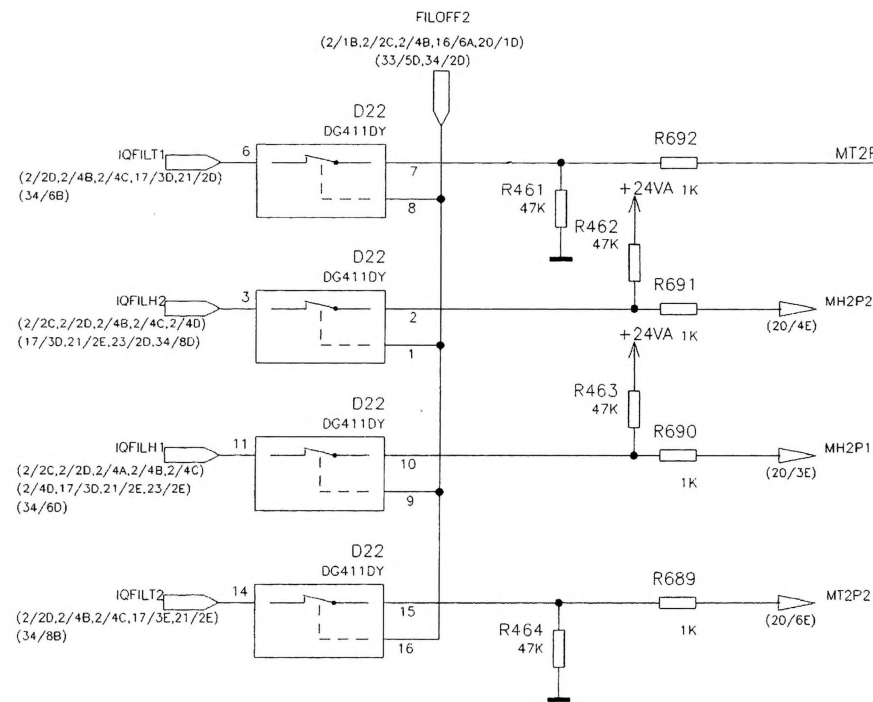
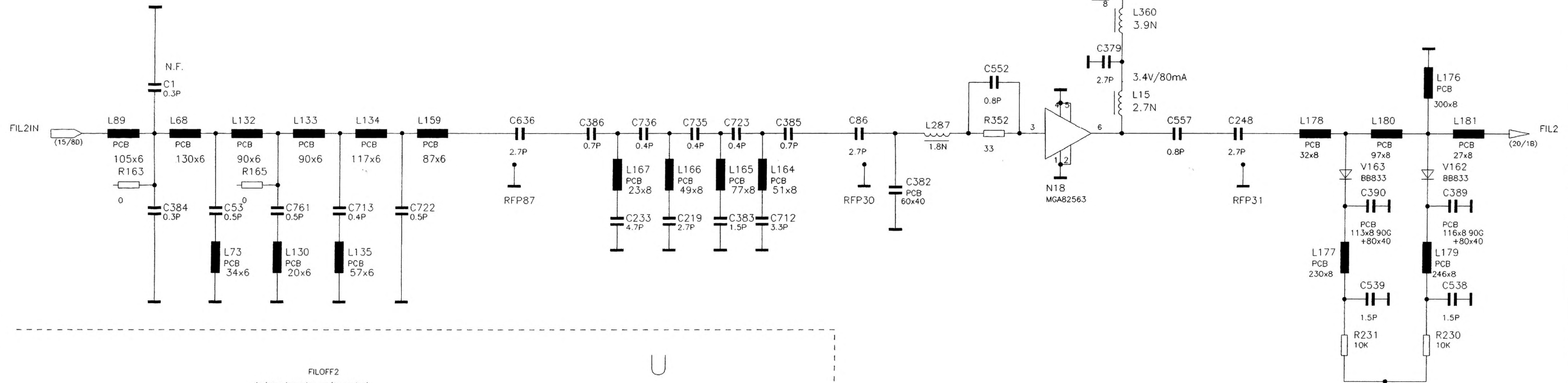

Bindende Angaben ueber Varianten, Trimmwerte, Bauteile und nicht bestueckte Bauteile siehe SA.

×× = NOT FITTED

FOR BINDING INFORMATION ON MODELS, TRIMMING AND COMPONENTS VALUES AND NONFITTED COMPONENTS SEE PARTS LIST

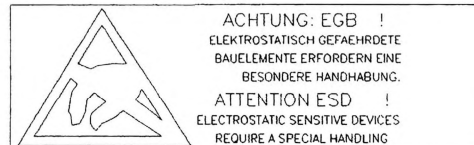

Benennung: 6-GHZ-ERWEITERUNG Designation: 6-GHZ-EXTENSION		Sprache: / Lang.: DE	Aei: / C.I.: 06.05	Blatt: / Sh.: 19+
Typ: SMIQ	Datum: 99-09-09	Name: HOFBERGE	Zeichn. Nr.: / Drawing No.: 1084.9600.01 S	
I. Z.: used in: 1084.8004.01		TOP/BAND2_34/BAND2.1		

r uer diese Unterlage benahten wir uns alle Rechte vor
For this document all rights are reserved

1

2

3

4

5

6

7

8

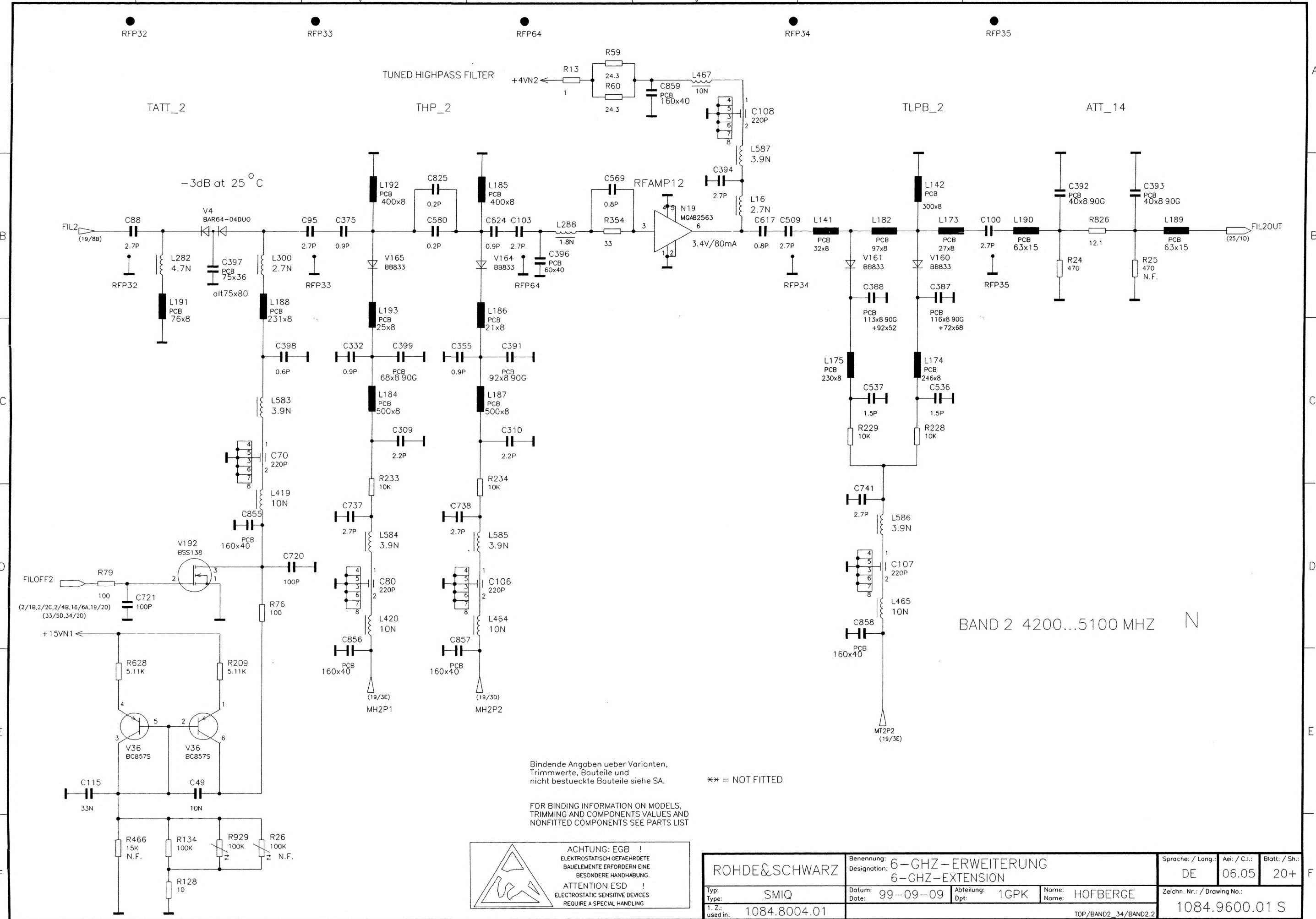

ruer diese Unterlage behalten wir uns alle Rechte vor
 For this document all rights are reserved

Bindende Angaben ueber Varianten,
 Trimmwerte, Bauteile und
 nicht bestueckte Bauteile siehe SA.

FOR BINDING INFORMATION ON MODELS,
 TRIMMING AND COMPONENTS VALUES AND
 NONFITTED COMPONENTS SEE PARTS LIST

ACHTUNG: EGB !
 ELEKTROSTATISCH GEFAEHRDETE
 BAUELEMENTE ERFORDERN EINE
 BESONDERE HANDHABUNG.
ATTENTION ESD !
 ELECTROSTATIC SENSITIVE DEVICES
 REQUIRE A SPECIAL HANDLING

ROHDE&SCHWARZ		Benennung: 6-GHZ-ERWEITERUNG		Sprache: / Lang.: DE		Aei: / C.I.: 06.05		Blatt: / Sh.: 20+	
Designation: 6-GHZ-ERWEITERUNG		Datum: 99-09-09		Abteilung: 1GPK		Name: HOFBERGE		Zeichn. Nr.: / Drawing No.: 1084.9600.01 S	
Type: SMIQ		Date: 99-09-09		Dpt: 1GPK		Name: HOFBERGE		TOP/BAND2_34/BAND2.2	
1. Z.: used in: 1084.8004.01									

BAND 2 4200...5100 MHZ N

BAND 3 5100...6000 MHZ

RFP36

RFP37

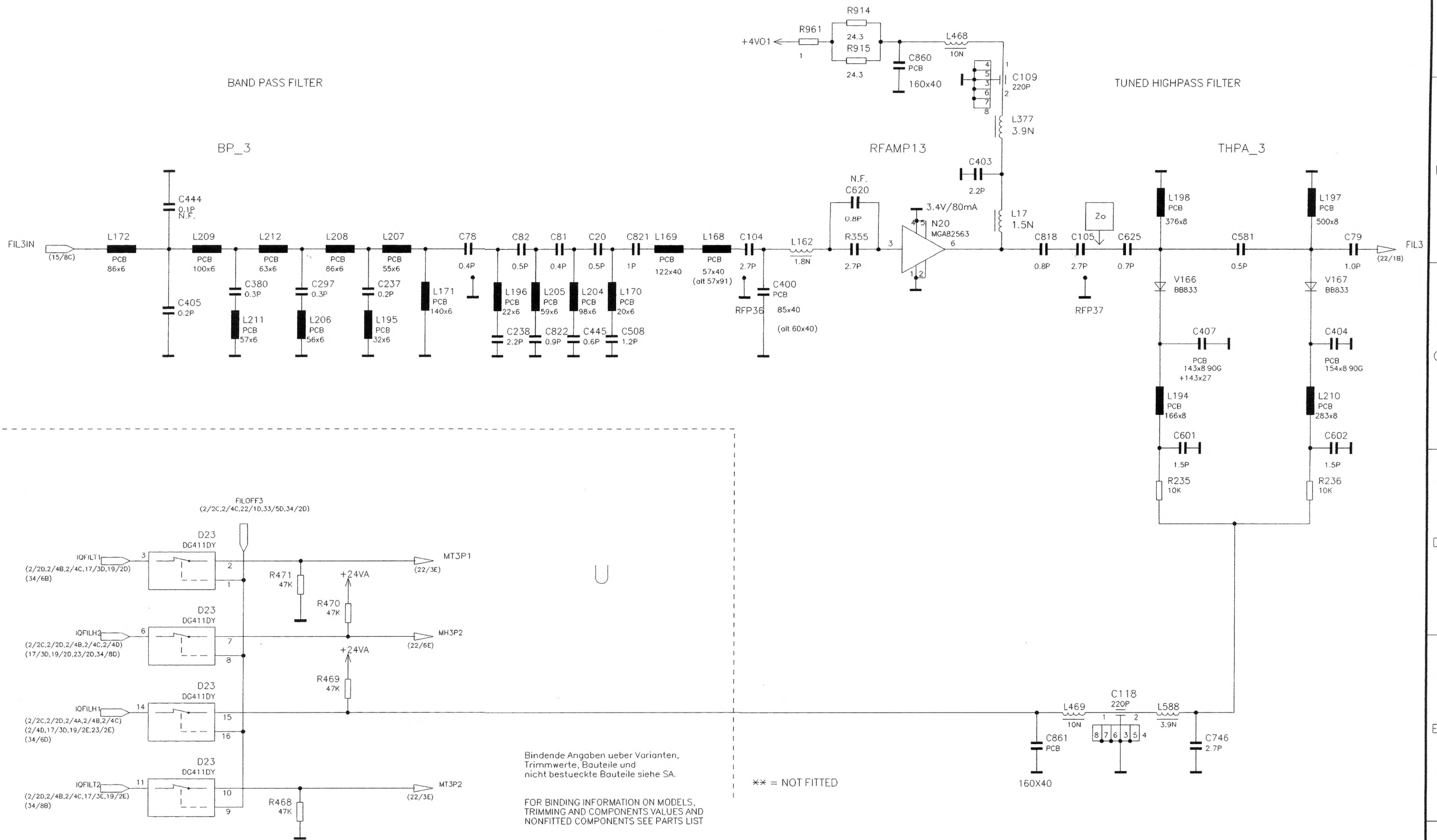

Für diese Unterlegungen behalten wir uns alle Rechte vor
For this document all rights are reserved

Bindende Angaben ueber Varianten,
Trimmwerte, Bauteile und
nicht bestueckte Bauteile siehe SA.

FOR BINDING INFORMATION ON MODELS,
TRIMMING AND COMPONENTS VALUES AND
NONFITTED COMPONENTS SEE PARTS LIST

** = NOT FITTED

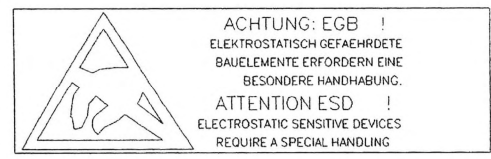

ROHDE&SCHWARZ		Benennung: 6-GHZ-ERWEITERUNG Designation: 6-GHZ-EXTENSION		Sprache: / Lang.: DE		Aei: / C.I.: 06.05		Blatt: / Sh.: 21+	
Typ: SMIQ		Datum: 99-09-09		Abteilung: 1GPK		Name: HOFBERGE		Zeichn. Nr.: / Drawing No.: 1084.9600.01 S	
T. Z.: used in: 1084.8004.01								TOP/BAND3_35/BAND3.1	

ruer diese Unterlage benaiten wir uns alle recnte vor
 For this document all rights are reserved

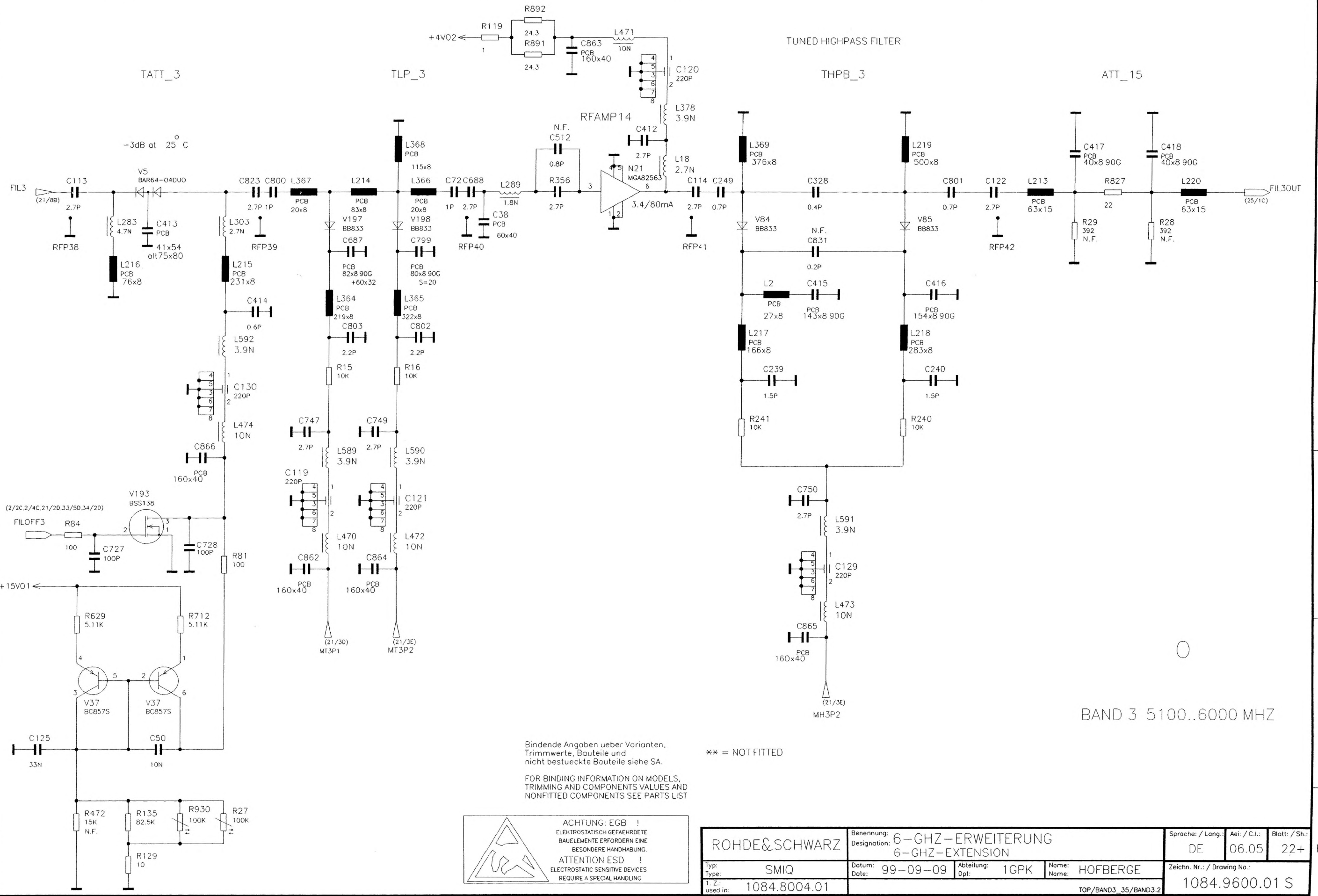

BAND 3 5100..6000 MHZ

Bindende Angaben ueber Varianten, Trimmwerte, Bauteile und nicht bestueckte Bauteile siehe SA. ** = NOT FITTED

FOR BINDING INFORMATION ON MODELS, TRIMMING AND COMPONENTS VALUES AND NONFITTED COMPONENTS SEE PARTS LIST

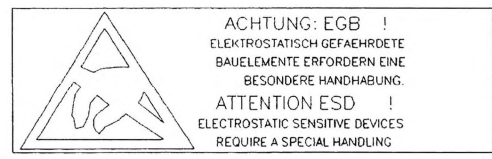

ROHDE&SCHWARZ Typ: SMIQ T. Z.: 1084.8004.01 used in:		Benennung: 6-GHZ-ERWEITERUNG Designation: 6-GHZ-EXTENSION Datum: 99-09-09 Date:	Abteilung: 1GPK Dpt: Name: HOFBERGE Name:	Sprache: / Lang.: DE Aei: / C.I.: 06.05 Blatt: / Sh.: 22+ Zeichn. Nr.: / Drawing No.: 1084.9600.01 S TOP/BAND3_35/BAND3.2
--	--	--	--	---

Für diese Unterlage behalten wir uns alle Rechte vor
For this document all rights are reserved

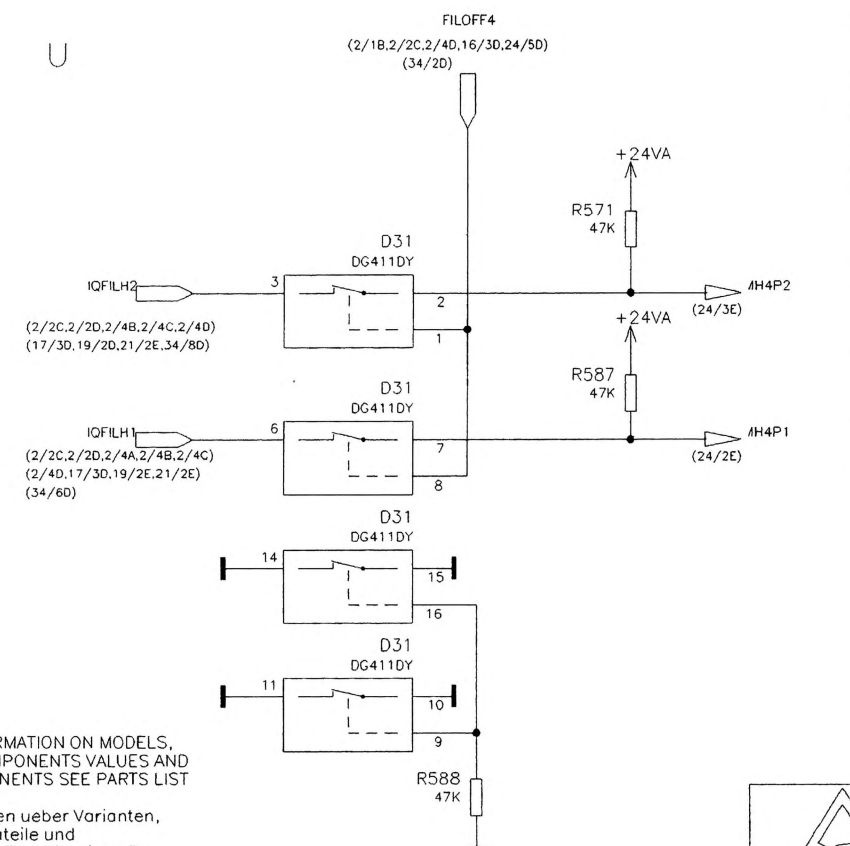
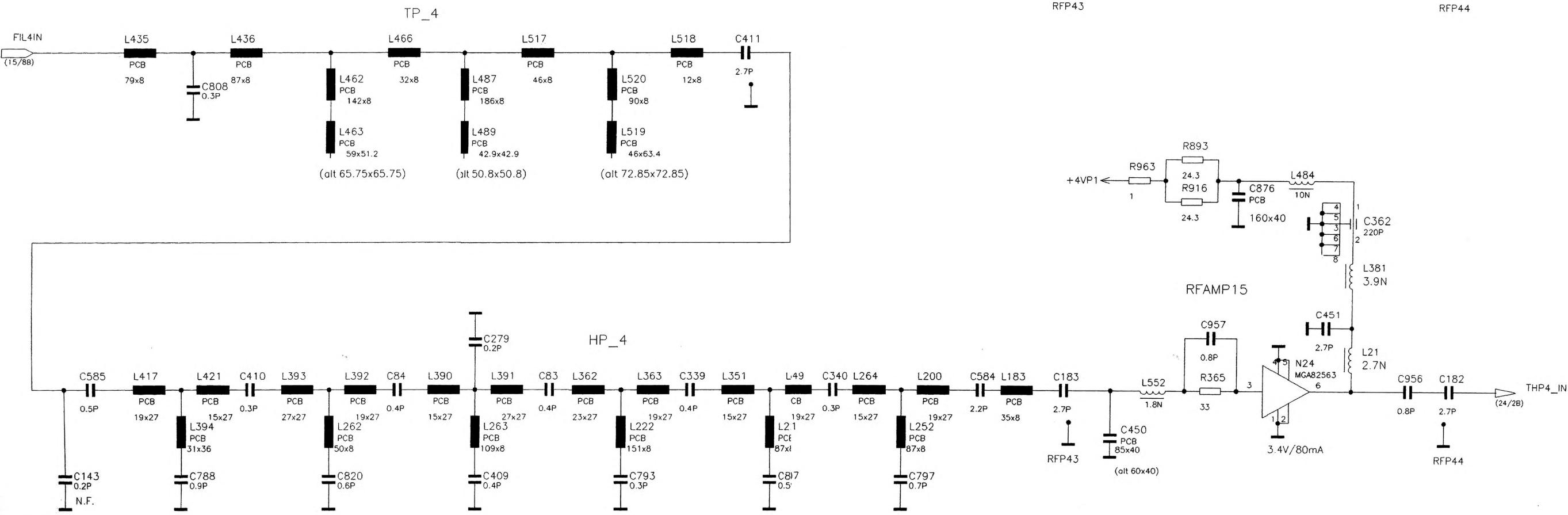

FOR BINDING INFORMATION ON MODELS, TRIMMING AND COMPONENTS VALUES AND NONFITTED COMPONENTS SEE PARTS LIST
Bindende Angaben ueber Varianten, Trimmwerte, Bauteile und nicht bestueckte Bauteile siehe SA.

ACHTUNG: EGB !
ELEKTROSTATISCH GEFÄHRDETE BAUELEMENTE ERFORDERN EINE BESONDERE HANDHABUNG.
ATTENTION ESD !
ELECTROSTATIC SENSITIVE DEVICES REQUIRE A SPECIAL HANDLING

ROHDE & SCHWARZ		Benennung: 6-GHZ-ERWEITERUNG Designation: 6-GHZ-EXTENSION		Sprache / Lang.: DE		Aei / C.I.: 06.05		Blatt / Sh.: 23+	
Typ: SMIQ		Datum: 99-09-09		Abteilung: 1GPK		Name: HOFBERGE		Zeichn. Nr. / Drawing No.: 1084.9600.01 S	
1. Z. used in: 1084.8004.01								TOP/BAND4_37/BAND4.1	

BAND4 6000...6400MHZ
P

** = NOT FITTED

fuer diese Unterlage behalten wir uns alle Rechte vor
 For this document all rights are reserved

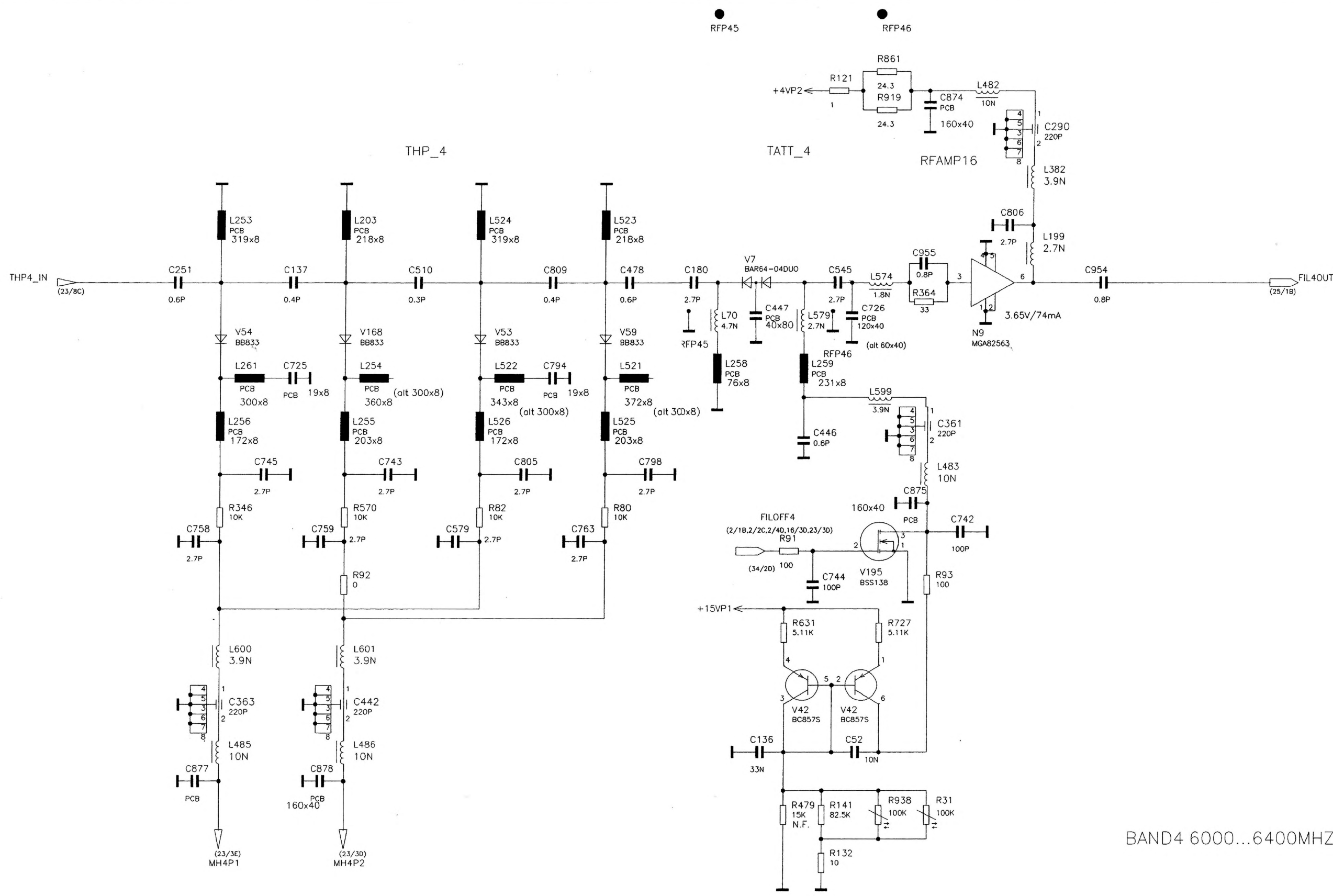

BAND4 6000...6400MHZ

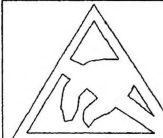
ACHTUNG: EGB !
 ELEKTROSTATISCH GEFÄHRDETE
 BAUELEMENTE ERFORDERN EINE
 BESONDERE HANDHABUNG.
ATTENTION ESD !
 ELECTROSTATIC SENSITIVE DEVICES
 REQUIRE A SPECIAL HANDLING

ROHDE&SCHWARZ		Benennung: 6-GHZ-ERWEITERUNG		Sprache: / Lang.: DE		Aei: / C.I.: 06.05		Blatt: / Sh.: 24+	
Designation: 6-GHZ-EXTENSION		Datum: 99-09-09		Abteilung: 1GPK		Name: HOFBERGE		Zeichn. Nr.: / Drawing No.: 1084.9600.01 S	
Typ: SMIQ		Date: 1084.8004.01		Dpt: TOP/BAND4_37/BAND4.2					
1. Z. used in:									

RFP48 ● RFP50
RFP49 ● RFP51

RFSWITCH2

● RFP52

● RFP53

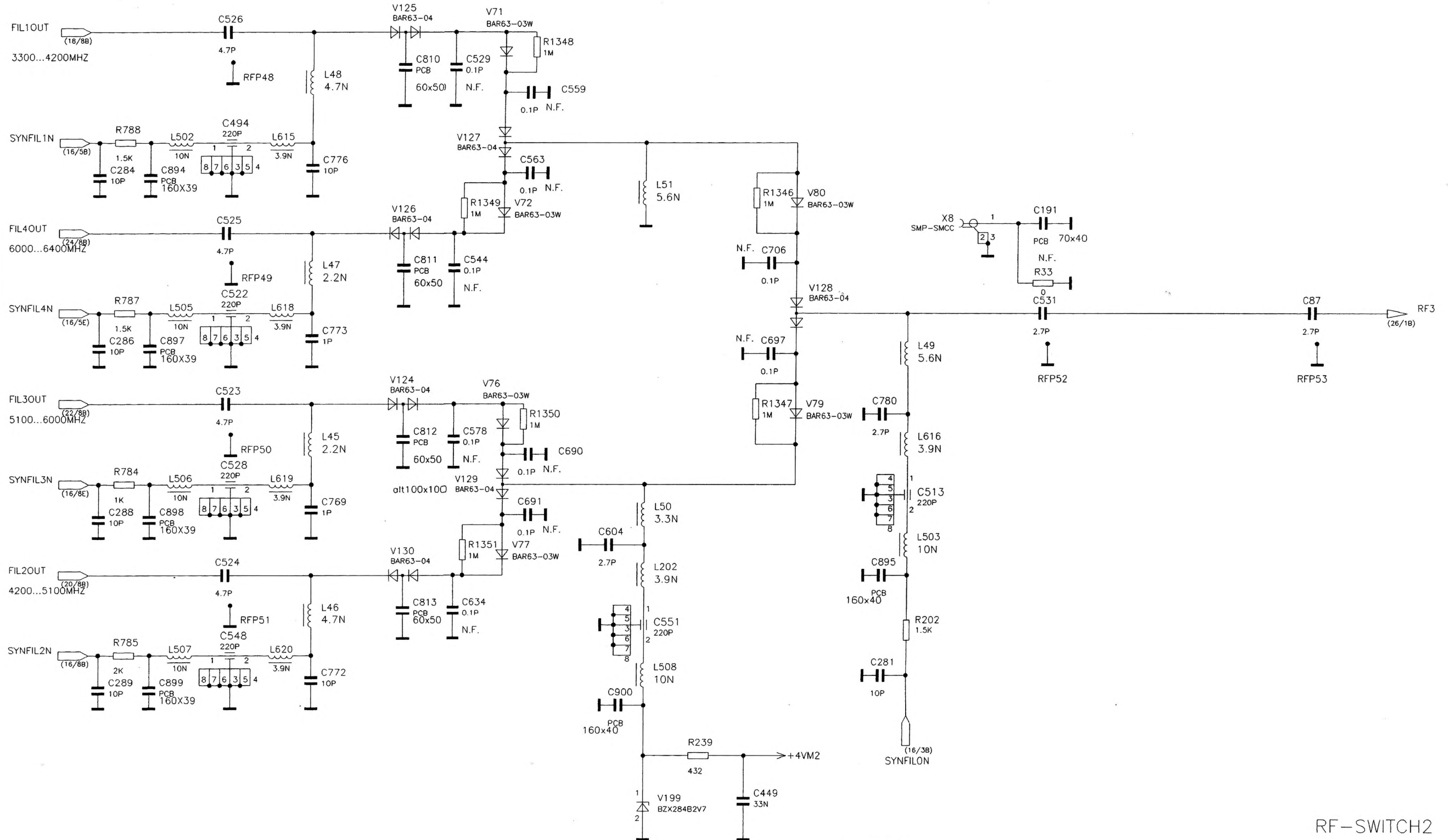

For this document all rights are reserved

Bindende Angaben ueber Varianten,
Trimmwerte, Bauteile und
nicht bestueckte Bauteile siehe SA.

FOR BINDING INFORMATION ON MODELS,
TRIMMING AND COMPONENTS VALUES AND
NONFITTED COMPONENTS SEE PARTS LIST

** = NOT FITTED

RF-SWITCH2 R

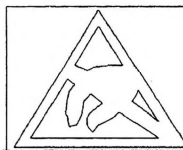

ACHTUNG: EGB !
ELEKTROSTATISCH GEFÄHRDETE
BAUELEMENTE ERFORDERN EINE
BESONDERE HANDHABUNG.
ATTENTION ESD !
ELECTROSTATIC SENSITIVE DEVICES
REQUIRE A SPECIAL HANDLING

ROHDE&SCHWARZ

Typ: SMIQ
Date: 99-09-09
I. Z.: 1084.8004.01

Benennung: 6-GHZ-ERWEITERUNG
Designation: 6-GHZ-EXTENSION

Date: 99-09-09
Abteilung: 1GPK
Name: HOFBERGE
TOP/RF-PREAMPLIFIER_AM-MODULATOR_56/RF-PREAMPLIFIER_AM-MODULATOR.1

Sprache / Lang.: DE
Aei / C.I.: 06.05
Blatt / Sh.: 25+

Zeichn. Nr. / Drawing No.: 1084.9600.01 S

Für diese Unterlage beanhalten wir uns alle Rechte vor
For this document all rights are reserved

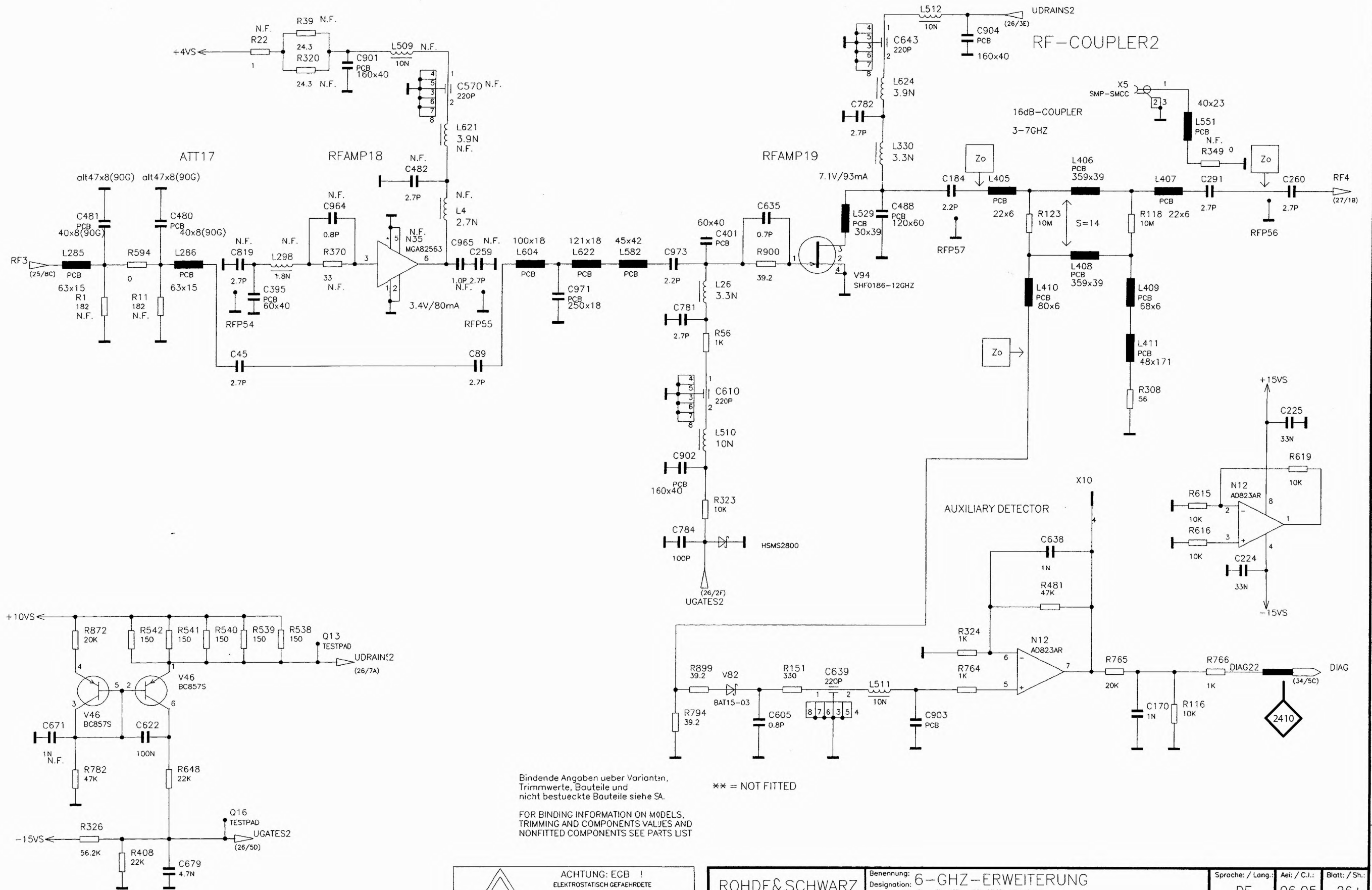

Bindende Angaben ueber Varianten,
Trimmwerte, Bauteile und
nicht bestueckte Bauteile siehe SA.
FOR BINDING INFORMATION ON MODELS,
TRIMMING AND COMPONENTS VALJES AND
NONFITTED COMPONENTS SEE PARTS LIST

** = NOT FITTED

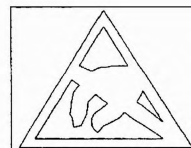

ACHTUNG: EGB !
ELEKTROSTATISCH GEFÄHRDETE
BAUELEMENTE ERFORDERN EINE
BESONDERE HANDHABUNG.
ATTENTION ESD !
ELECTROSTATIC SENSITIVE DEVICES
REQUIRE A SPECIAL HANDLING

ROHDE&SCHWARZ Typ: SMIQ used in: 1084.8004.01		Benennung: 6-GHZ-ERWEITERUNG Designation: 6-GHZ-EXTENSION Datum: 99-09-09 Dept: 1GPK Name: HOFBERGE		Sprache: / Lang.: DE Ael: / C.I.: 06.05 Blatt: / Sh.: 26+ Zeichn. Nr.: / Drawing No.: 1084.9600.01 S	
TOP/RF-PREAMPLIFIER_AM-MODULATOR_56/RF-PREAMPLIFIER_AM-MODULATOR.2					

AM-MODULATOR_1

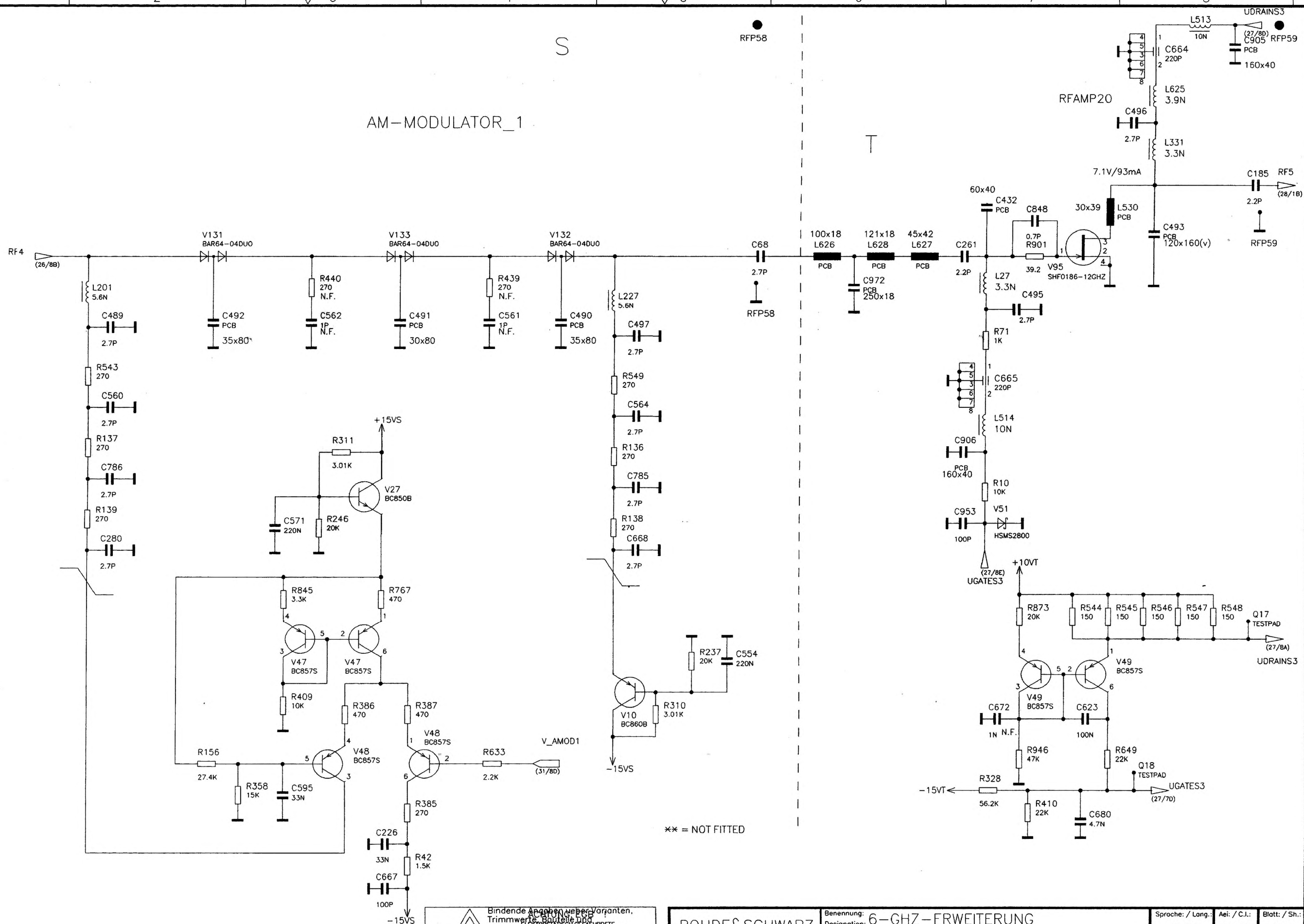

Für diese Unterlage behalten wir uns alle Rechte vor
For this document all rights are reserved

** = NOT FITTED

Bindende Angaben über Varianten,
ACHTUNG! Trimmwerte, Bauteile und
Elektronische Bauelemente sind
nicht beständig. Für die richtige
Bauelemente-Identifizierung
SIEHERHEITSSYMBOL
FOR BINDING INFORMATION ON MODELS,
TRIMMING AND COMPONENTS VALUES AND
NON-FITTED COMPONENTS SEE PARTS LIST
REQUIRE A SPECIAL HANDLING

ROHDE & SCHWARZ Typ: SMIQ I. Z.: 1084.8004.01		Benennung: 6-GHZ-ERWEITERUNG Designation: 6-GHZ-EXTENSION Datum: 99-09-09 Abteilung: 1GPK Name: HOFBERGE		Sprache: / Lang.: DE Aei: / C.I.: 06.05 Blatt: / Sh.: 27+ Zeichn. Nr.: / Drawing No.: 1084.9600.01 S	
TOP/RF-PREAMPLIFIER AM-MODULATOR_56/RF-PREAMPLIFIER AM-MODULATOR_3					

AM-MODULATOR_2

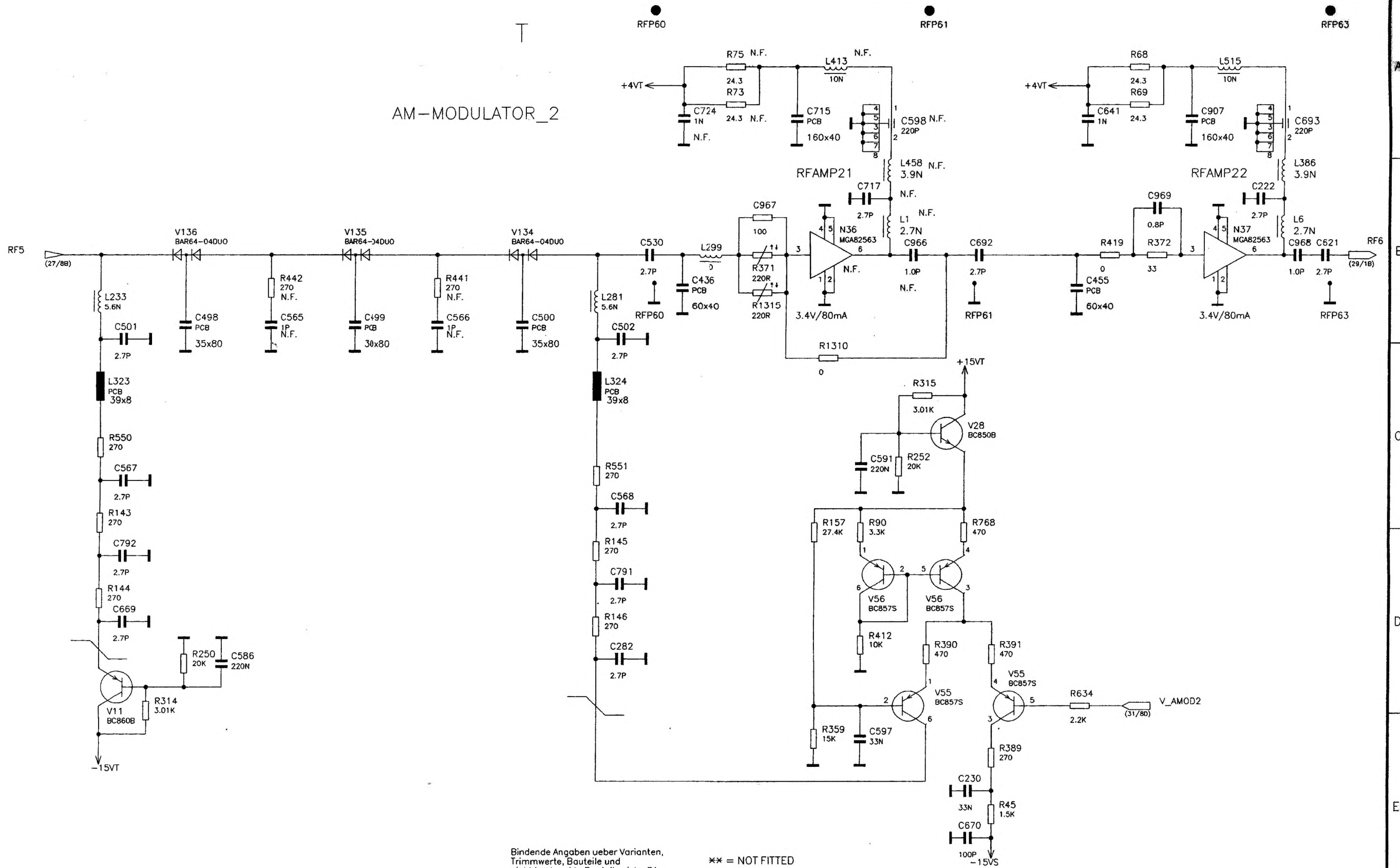

ruer diese Unterlegte benützen wir uns alle Rechte vor.
 For this document all rights are reserved

Bindende Angaben ueber Varianten,
 Trimmwerte, Bauteile und
 nicht bestueckte Bauteile siehe SA.
 FOR BINDING INFORMATION ON MODELS,
 TRIMMING AND COMPONENTS VALUES AND
 NONFITTED COMPONENTS SEE PARTS LIST

*** = NOT FITTED



ROHDE & SCHWARZ		Benennung: 6-GHZ-ERWEITERUNG Designation: 6-GHZ-EXTENSION		Sprache / Lang.: DE		Aei / C.I.: 06.05		Blatt / Sh.: 28+	
Typ: SMIQ		Datum: 99-09-09		Abteilung: 1GPK		Name: HOFBERGE		Zeichn. Nr.: / Drawing No.: 1084.9600.01 S	
1. Z.: 1084.8004.01		TOP/RF-PREAMPLIFIER_AM-MODULATOR_56/RF-PREAMPLIFIER_AM-MODULATOR_4							

In case of a discrepancy between this document and the original drawing, the original drawing shall prevail.
Für dieses Urheberrecht vorbehalten mit allen Rechten vorbehalten.
For this document all rights are reserved.

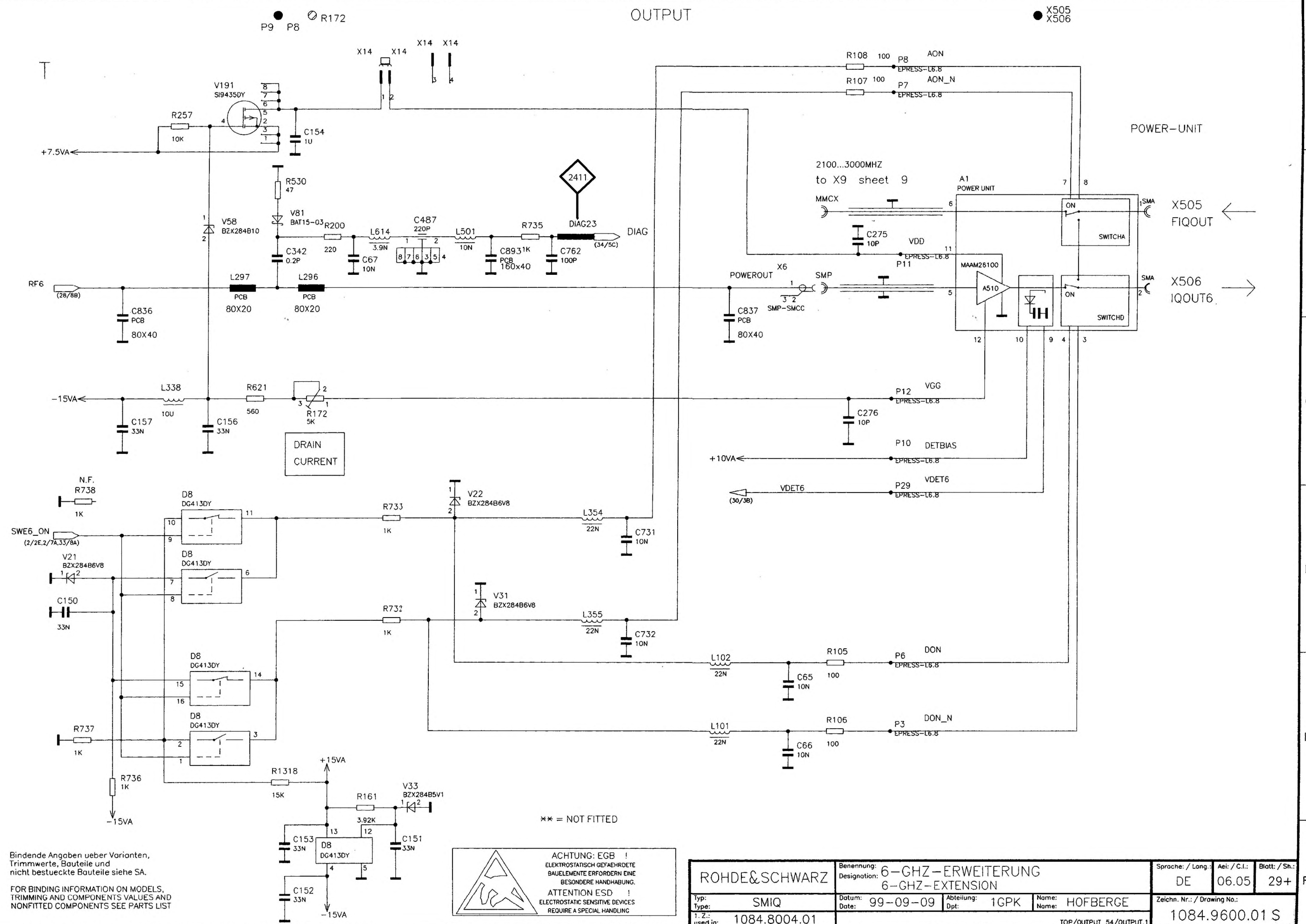

** = NOT FITTED

Bindende Angaben ueber Varianten, Trimmwerte, Bauteile und nicht bestueckte Bauteile siehe SA.
FOR BINDING INFORMATION ON MODELS, TRIMMING AND COMPONENTS VALUES AND NONFITTED COMPONENTS SEE PARTS LIST

ACHTUNG: EGB !
ELEKTROSTATISCH GEFAEHRDETE BAUELEMENTE ERFORDERN EINE BESONDERE HANDHABUNG.
ATTENTION ESD !
ELECTROSTATIC SENSITIVE DEVICES REQUIRE A SPECIAL HANDLING

ROHDE&SCHWARZ		Benennung: 6-GHZ-ERWEITERUNG Designation: 6-GHZ-EXTENSION	Sprache: / Lang.: DE	Aei: / C.I.: 06.05	Blatt: / Sn.: 29+
Type: SMIQ	Date: 99-09-09	Abteilung: 1GPK	Name: HOFBERGE	Zeichn. Nr.: / Drawing No.: 1084.9600.01 S	
used in: 1084.8004.01	TOP/OUTPUT_54/OUTPUT.1				

rueer diese unterlage denaiten wir uns alle recnte vor
For this document all rights are reserved

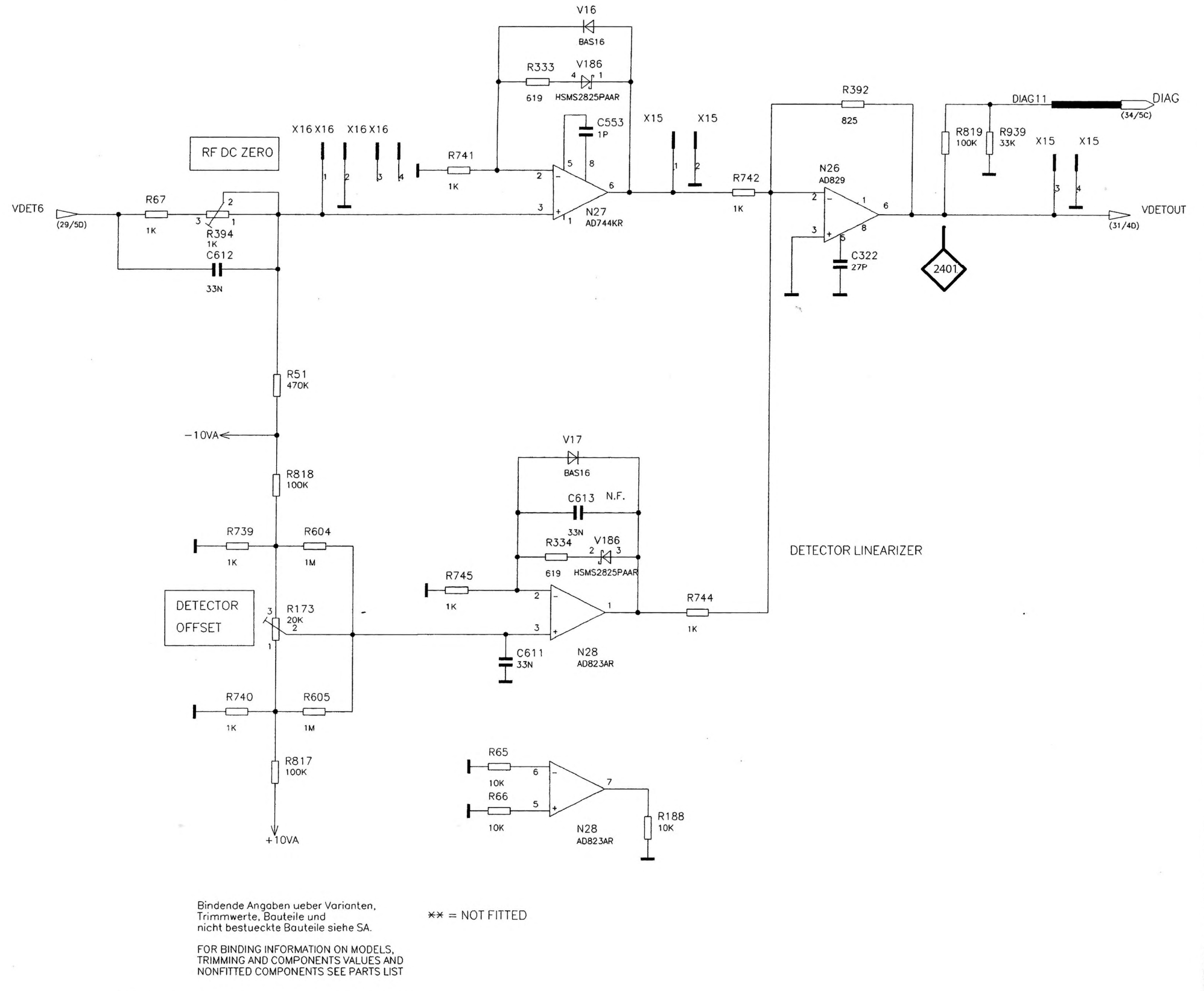

Bindende Angaben ueber Varianten,
Trimmwerte, Bauteile und
nicht bestueckte Bauteile siehe SA.

** = NOT FITTED

FOR BINDING INFORMATION ON MODELS,
TRIMMING AND COMPONENTS VALUES AND
NONFITTED COMPONENTS SEE PARTS LIST

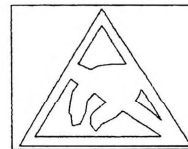

ACHTUNG: EGB !
ELEKTROSTATISCH GEFAEHRDETE
BAUELEMENTE ERFORNERN EINE
BESONDERE HANDHABUNG.
ATTENTION ESD !
ELECTROSTATIC SENSITIVE DEVICES
REQUIRE A SPECIAL HANDLING

ROHDE&SCHWARZ Typ: SMIQ 1. Z.: 1084.8004.01 used in:		Benennung: 6-GHZ-ERWEITERUNG Designation: 6-GHZ-EXTENSION Datum: 99-09-09 Dpt: 1GPK		Name: HOFBERGE Abteilung: 1GPK Sproche: / Lang.: DE Aei: / C.I.: 06.05 Blatt: / Sh.: 30+	
TOP/OUTPUT_54/OUTPUT.2				Zeichn. Nr.: / Drawing No.: 1084.9600.01 S	

X500

P16
P17

A T OUTPUT

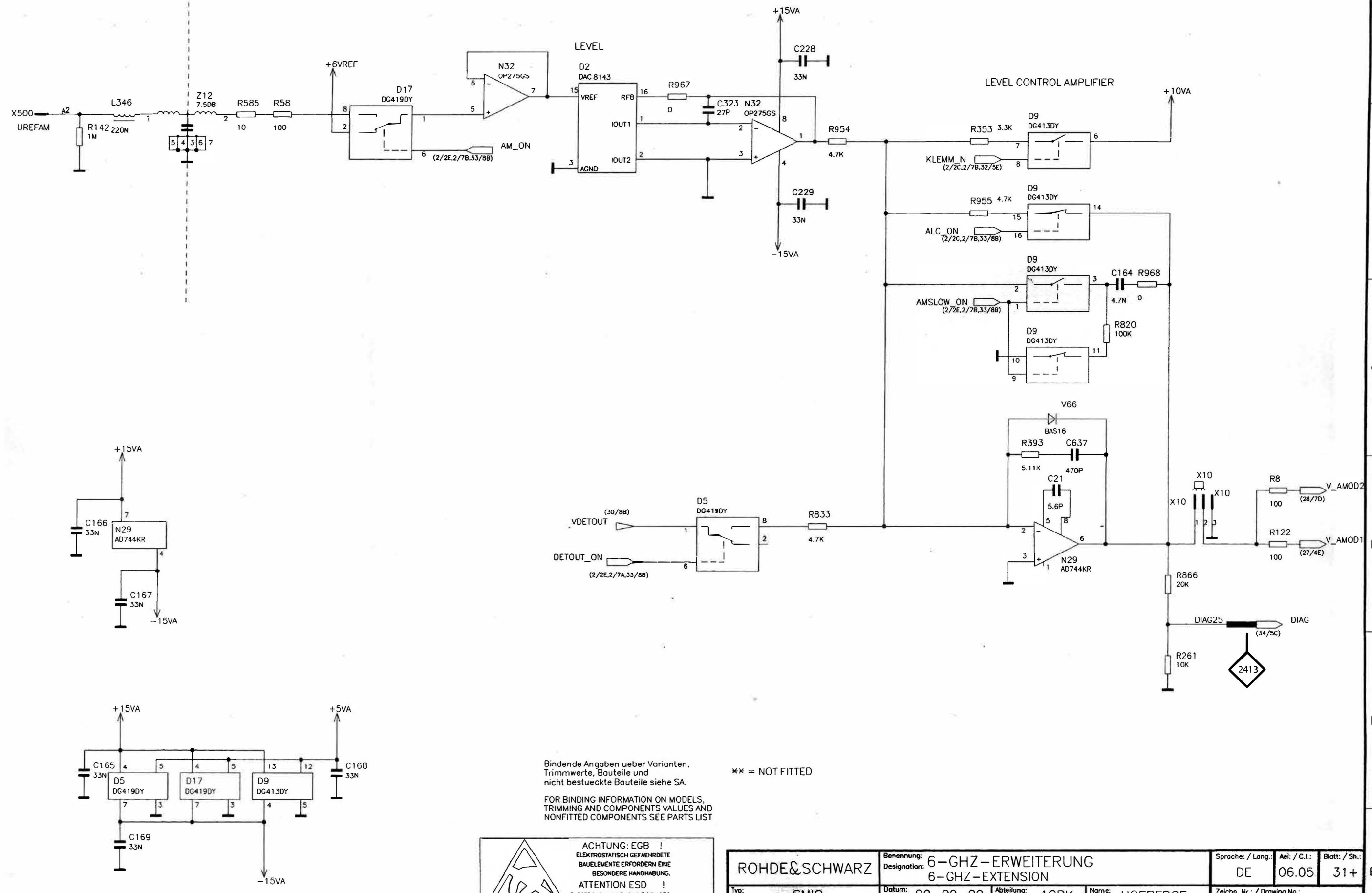

r uer diese Unterlage behalten wir uns alle Rechte vor
For this document all rights are reserved

Bindende Angaben ueber Varianten, Trimmwerte, Bauteile und nicht bestueckte Bauteile siehe SA. ** = NOT FITTED

FOR BINDING INFORMATION ON MODELS, TRIMMING AND COMPONENTS VALUES AND NONFITTED COMPONENTS SEE PARTS LIST

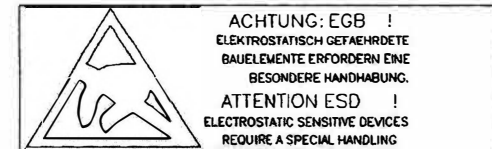

ROHDE & SCHWARZ Typ: SMIQ 1. Z.: 1084.8004.01		Benennung: 6-GHZ-ERWEITERUNG Designation: 6-GHZ-EXTENSION Datum: 99-09-09 Abteilung: 1GPK Dpt: HOFBERGE		Sprache: / Lang.: DE Ael: / C.I.: 06.05 Blatt: / Sh.: 31+ Zeichn. Nr.: / Drawing No.: 1084.9600.01 S	
		TOP/OUTPUT_54/OUTPUT_3			

r uer diese Untertage benaiten wir uns alle rechte vor
 For this document all rights are reserved

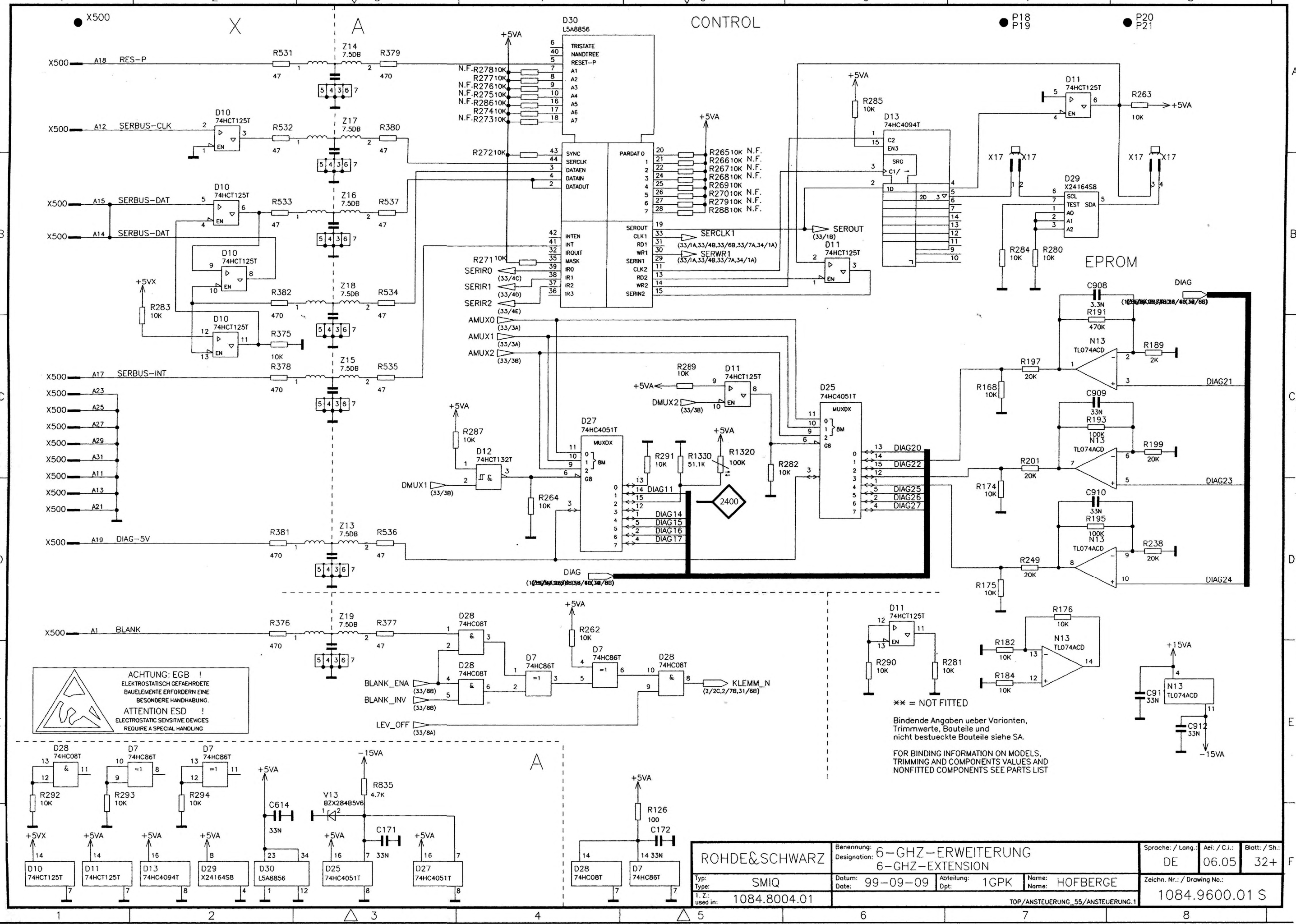

ACHTUNG: EGB !
 ELEKTROSTATISCH GEFAEHRDETE
 BAUELEMENTE ERFORDERN EINE
 BESONDERE HANDHABUNG.
ATTENTION ESD !
 ELECTROSTATIC SENSITIVE DEVICES
 REQUIRE A SPECIAL HANDLING

** = NOT FITTED
 Bindende Angaben ueber Varianten,
 Trimmwerte, Bauteile und
 nicht bestueckte Bauteile siehe SA.
 FOR BINDING INFORMATION ON MODELS,
 TRIMMING AND COMPONENTS VALUES AND
 NONFITTED COMPONENTS SEE PARTS LIST

ROHDE&SCHWARZ Typ: SMIQ T. Z.: 1084.8004.01		Benennung: 6-GHZ-ERWEITERUNG Designation: 6-GHZ-EXTENSION Datum: 99-09-09 Dpt: 1GPK		Sprache / Lang.: DE Aet / C.I.: 06.05 Name: HOFBERGE Zeichn. Nr. / Drawing No.: 1084.9600.01 S		Blatt / Sh.: 32+	
TOP/ANSTEUERUNG_55/ANSTEUERUNG.1							

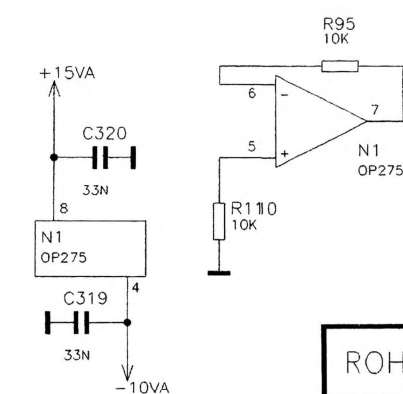
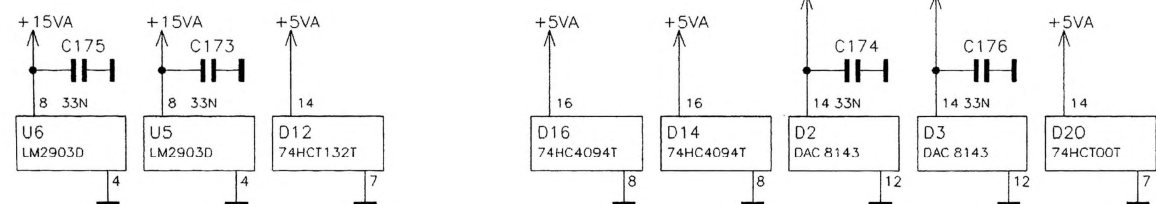
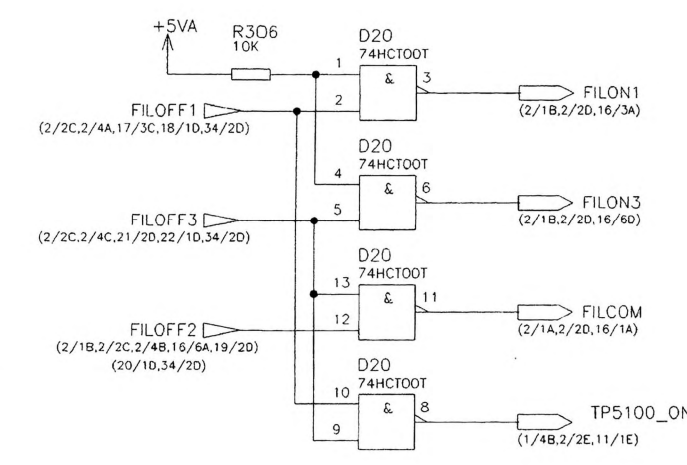
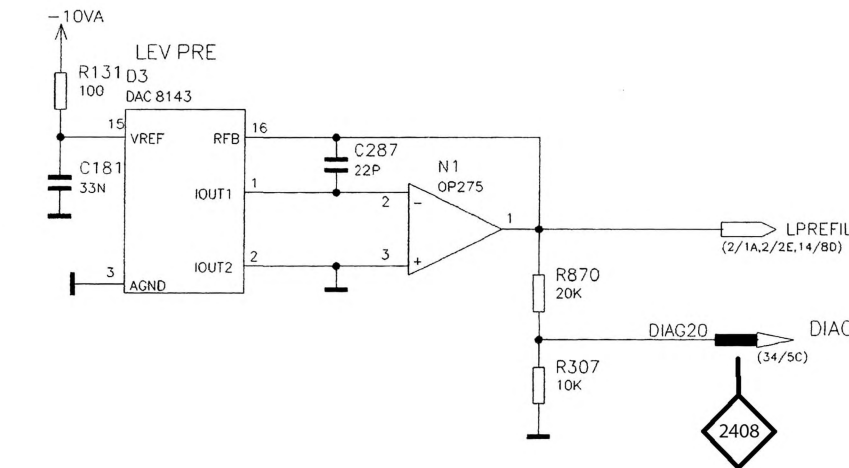
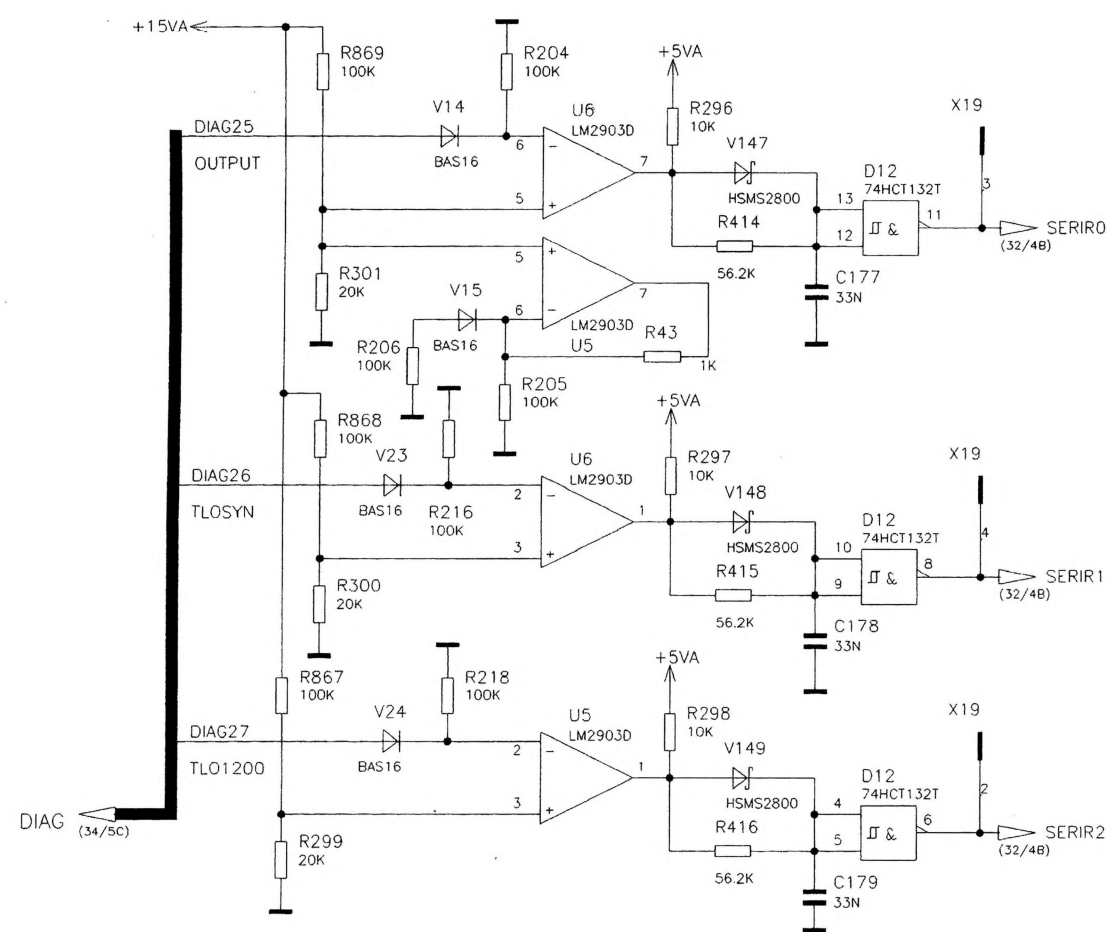
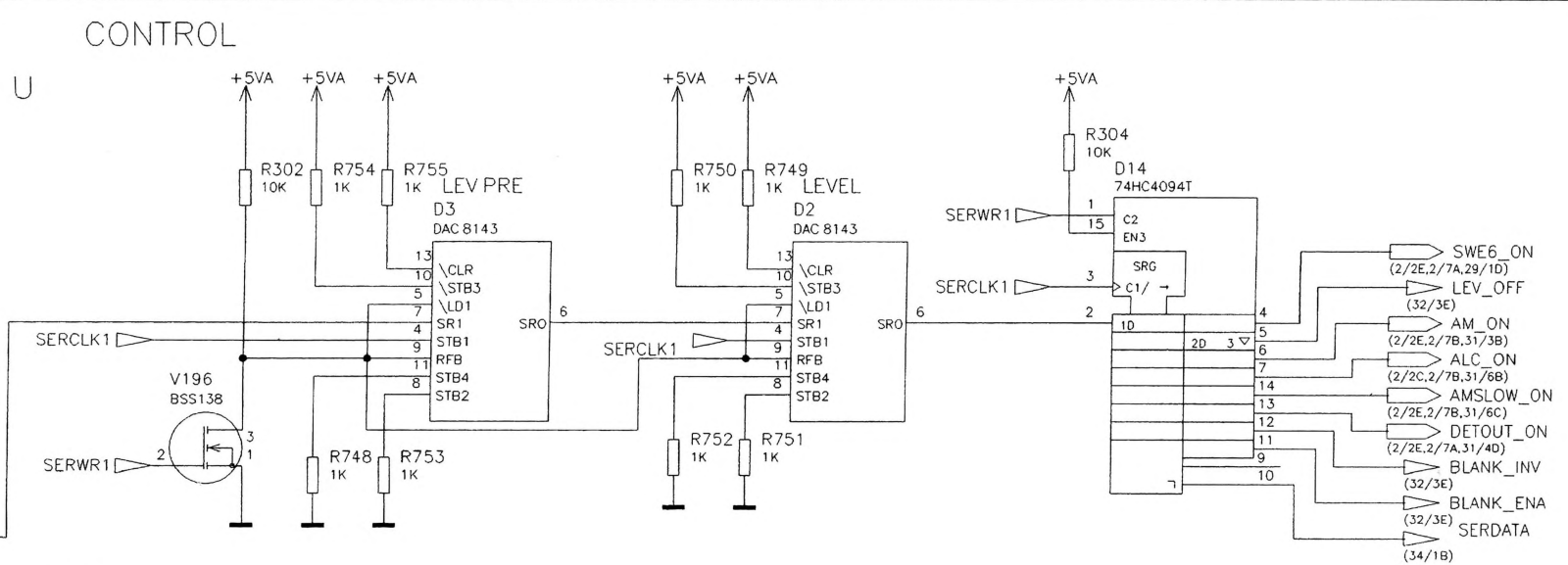
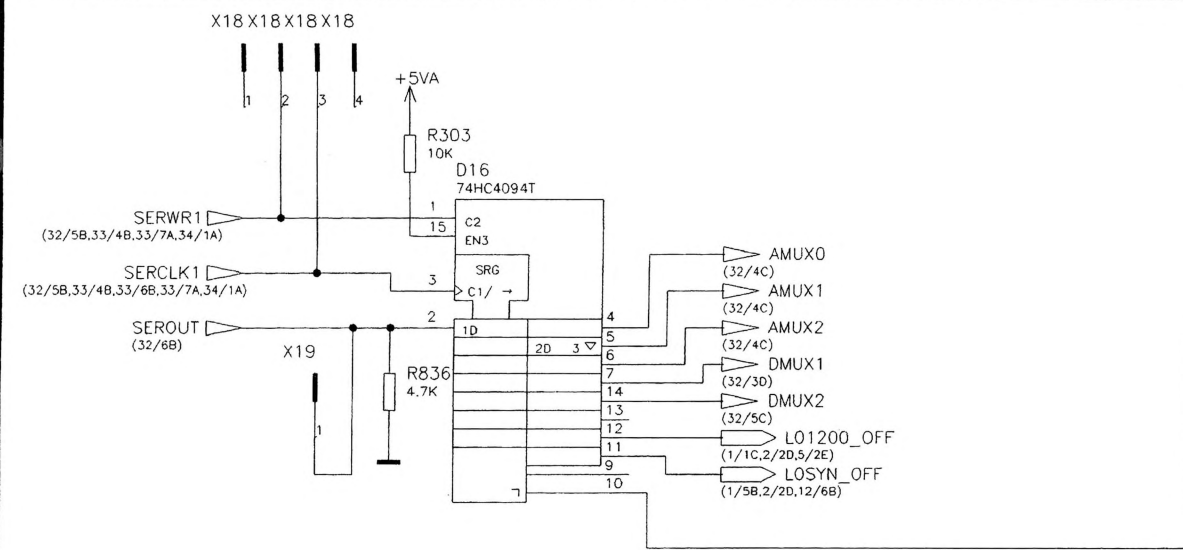

Bindende Angaben ueber Varianten, Trimmwerte, Bauteile und nicht bestueckte Bauteile siehe SA.
 FOR BINDING INFORMATION ON MODELS, TRIMMING AND COMPONENTS VALUES AND NONFITTED COMPONENTS SEE PARTS LIST

** = NOT FITTED

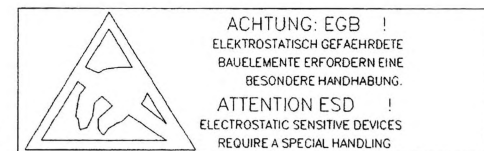

ROHDE&SCHWARZ		Benennung: 6-GHZ-ERWEITERUNG Designation: 6-GHZ-EXTENSION		Sprache: / Lang.: DE		Aei: / C.I.: 06.05		Blatt: / Sh.: 33+	
Typ: SMIQ		Datum: 99-09-09		Abteilung: 1GPK		Name: HOFBERGE		Zeichn. Nr.: / Drawing No.: 1084.9600.01 S	
I. Z.: 1084.8004.01								TOP/ANSTEUERUNG_55/ANSTEUERUNG.2	

r uer diese Unterlage behalten wir uns alle Rechte vor
 For this document all rights are reserved

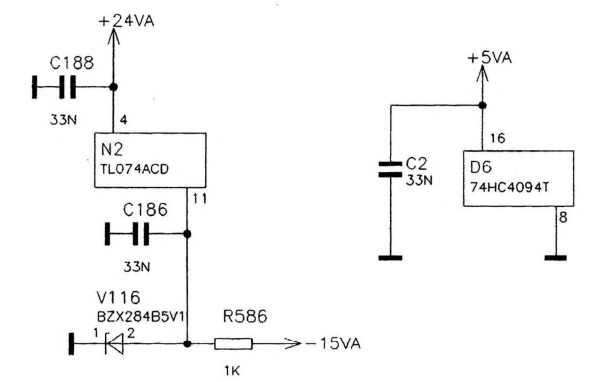
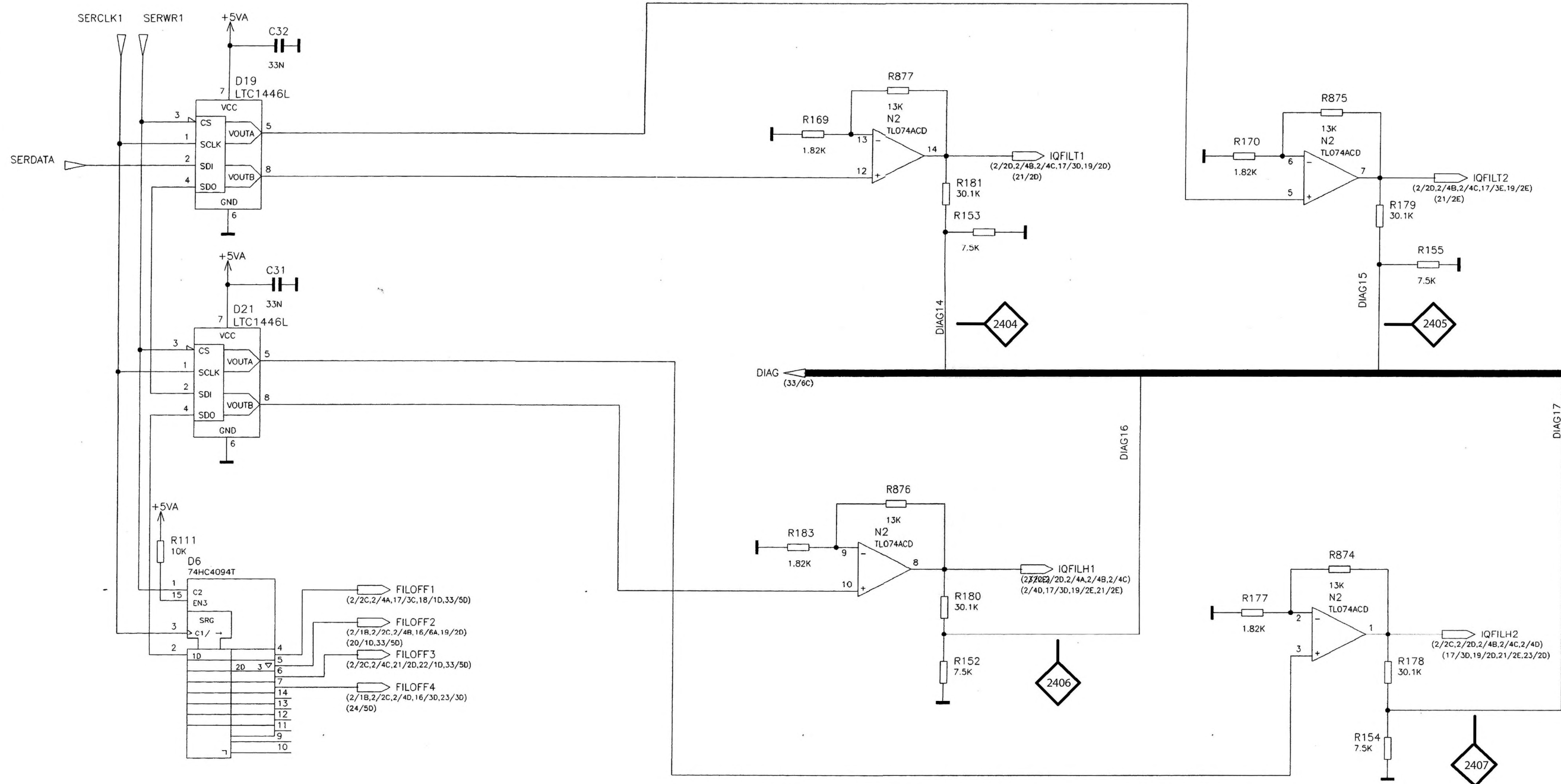

Bindende Angaben ueber Varianten, Trimmwerte, Bauteile und nicht bestueckte Bauteile siehe SA.
 FOR BINDING INFORMATION ON MODELS, TRIMMING AND COMPONENTS VALUES AND NONFITTED COMPONENTS SEE PARTS LIST

ACHTUNG: EGB !
 ELEKTROSTATISCH GEFAEHRDETE BAUELEMENTE ERFORDERN EINE BESONDERE HANDHABUNG.
ATTENTION ESD !
 ELECTROSTATIC SENSITIVE DEVICES REQUIRE A SPECIAL HANDLING

** = NOT FITTED

fuer diese Unterlage behalten wir uns alle Rechte vor
 For this document all rights are reserved

ROHDE&SCHWARZ		Benennung: 6-GHZ-ERWEITERUNG Designation: 6-GHZ-EXTENSION		Sprache / Lang.: DE Aei / C.I.: 06.05 Blatt / Sh.: 34+	
Typ: SMIQ Date: 99-09-09 1. Z.: 1084.8004.01		Abteilung: 1GPK Name: HOFBERGE		Zeichn. Nr.: / Drawing No.: 1084.9600.01 S	
TOP/ANSTEUERUNG_55/ANSTEUERUNG.3					

r. uer diese Unterlage behalten wir uns alle Rechte vor
 For this document all rights are reserved

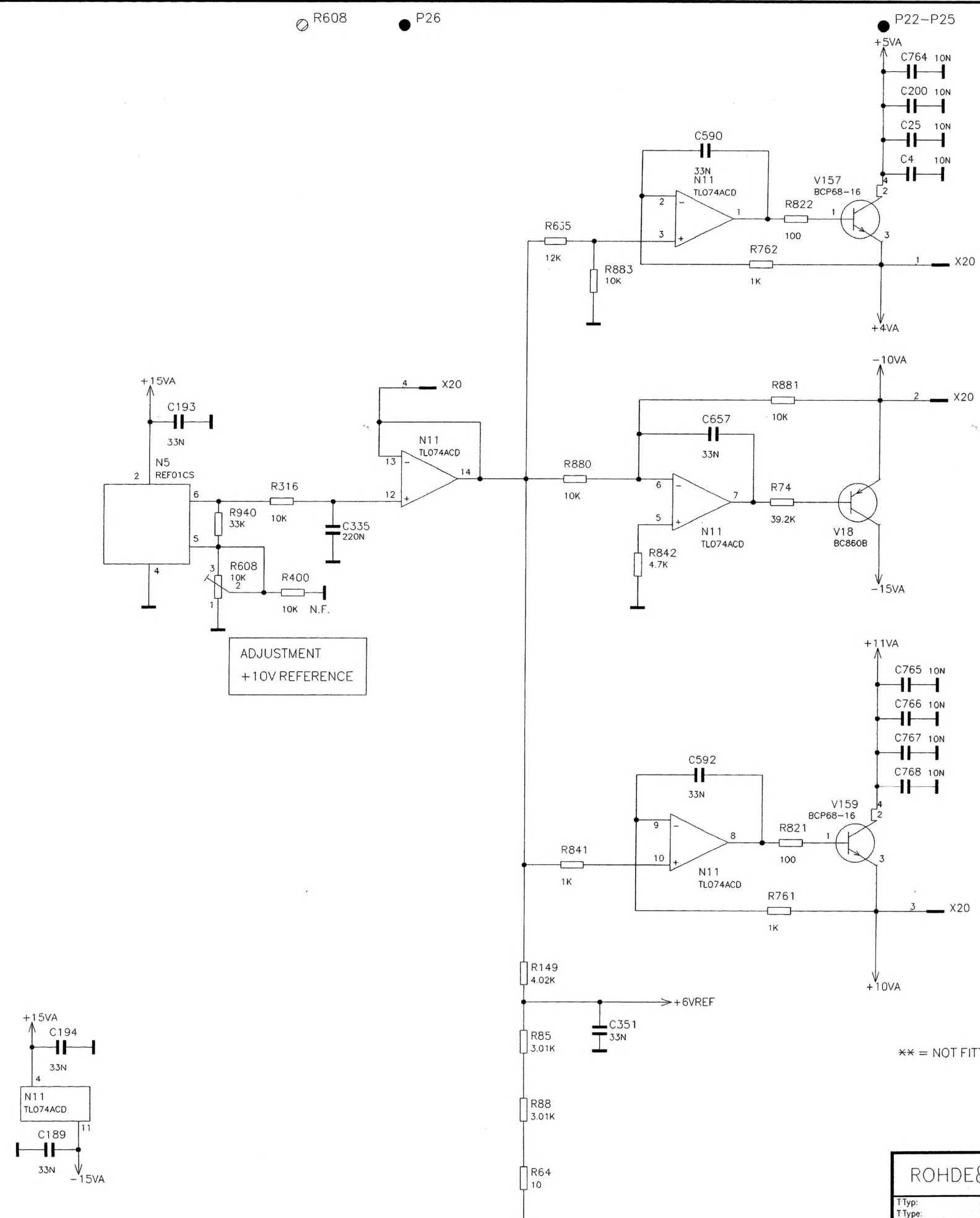

REFERENCE VOLTAGE

ADJUSTMENT
+10V REFERENCE

Bindende Angaben ueber Varianten,
Trimmwerte, Bauteile und
nicht bestueckte Bauteile siehe SA.

FOR BINDING INFORMATION ON MODELS,
TRIMMING AND COMPONENTS VALUES AND
NONFITTED COMPONENTS SEE PARTS LIST



ACHTUNG: EGB !
 ELEKTROSTATISCH GEFAEHRDETE
 BAUELEMENTE ERFORDERN EINE
 BESONDERE HANDHABUNG.
 ATTENTION ESD !
 ELECTROSTATIC SENSITIVE DEVICES
 REQUIRE A SPECIAL HANDLING

ROHDE&SCHWARZ		Benennung: 6-GHZ-ERWEITERUNG Designation: 6-GHZ-EXTENSION		Sprache: / Lang.: DE	Aei: / C.I.: 06.05	Blatt: / Sh.: 35+
T Typ: SMIQ		Datum: 99-09-09		Abteilung: 1GPK		Name: HOFBERGE
11. Z.: 1084.8004.01		used in: TOP/ANSTEUERUNG_55/ANSTEUERUNG.4		Zeichn. Nr.: / Drawing No.: 1084.9600.01 S		

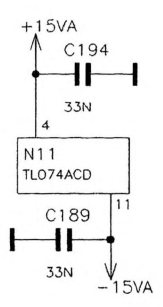

** = NOT FITTED

Für diese Unterlage benannt wir uns alle Rechte vor
 For this document all rights are reserved

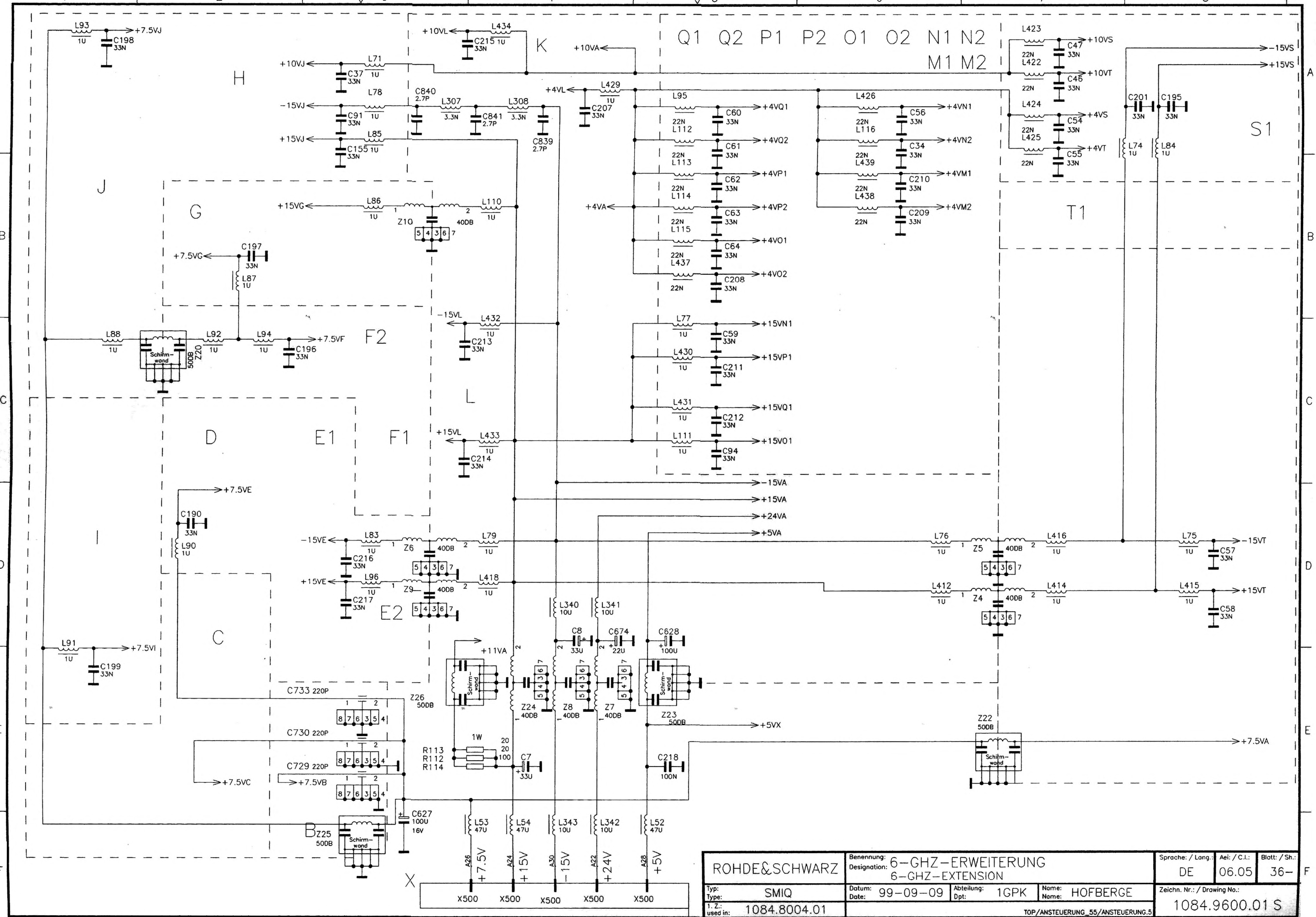

ROHDE & SCHWARZ		Benennung: 6-GHZ-ERWEITERUNG Designation: 6-GHZ-EXTENSION		Sprache: / Lang.: DE		Aei: / C.I.: 06.05		Blatt: / Sh.: 36-	
Typ: SMIQ		Datum: 99-09-09		Abteilung: 1GPK		Name: HOFBERGE		Zeichn. Nr.: / Drawing No.: 1084.9600.01 S	
1. Z.: used in: 1084.8004.01								TOP/ANSTEUERUNG_55/ANSTEUERUNG.S	

POWER-UNIT 1084.9500.02 with
 11ST. Ø88.0024 and
 11ST. Ø05.0280 and
 5ST. Ø48.6496 screws.

- The power unit should be mounted in the following order:
1. Fix power unit by means of screws 1+2 (tighten screws only lightly.)
 2. Lay and connect cables.
 3. Mount top cover and fix power unit by means of screws 3+4 (front side, next SMA connector)
 4. Tighten screws 1+2 with 60 Ncm
 5. Remove top cover.
 6. Wire eight lead-through filters of power unit with PCB (include strain relief).
 7. Mount top and bottom covers and tighten all remaining screws with 60Ncm. (7 tms Ø88.0024 + Ø05.0280 on components side, 5 tms Ø48.6496 on soldered side.)

POWER-UNIT 1084.9500.02 MIT
 11ST. Ø88.0024 UND
 11ST. Ø05.0280 UND
 5ST. Ø48.6496 VERSCHRAUBEN.

- DIE POWER-UNIT SOLLTE NACH FOLGENDER REIHENFOLGE MONTIERT WERDEN:
1. POWER-UNIT MIT SCHRAUBE 1+2 BEFESTIGEN. (SCHRAUBEN NUR LEICHT ANZIEHEN.)
 2. KABEL VERLEGEN UND EINSTECKEN.
 3. DECKEL OBEN BESTUECKEN, UND POWER-UNIT MIT SCHRAUBE 3+4 BEFESTIGEN. (STIRNSEITE, NEBEN SMA STECKER)
 4. SCHRAUBE 1+2 MIT 60Ncm FESTZIEHEN.
 5. DECKEL OBEN WIEDER ENTFERNEN.
 6. 8 X DURCHFUEHRUNGSFILTER DER POWER-UNIT MIT LP VERDRAHTEN. (MIT ZUGENTLASTUNG)
 7. WENN DIE DECKEL OBEN UND UNTEN MONTIERT WERDEN, ALLE RESTLICHEN SCHRAUBEN MIT 60Ncm FESTZIEHEN. (7 ST. Ø88.0024 + Ø05.0280 AUF BAUTEILSEITE, 5 ST. Ø48.6496 AUF LOETSEITE.)

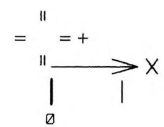
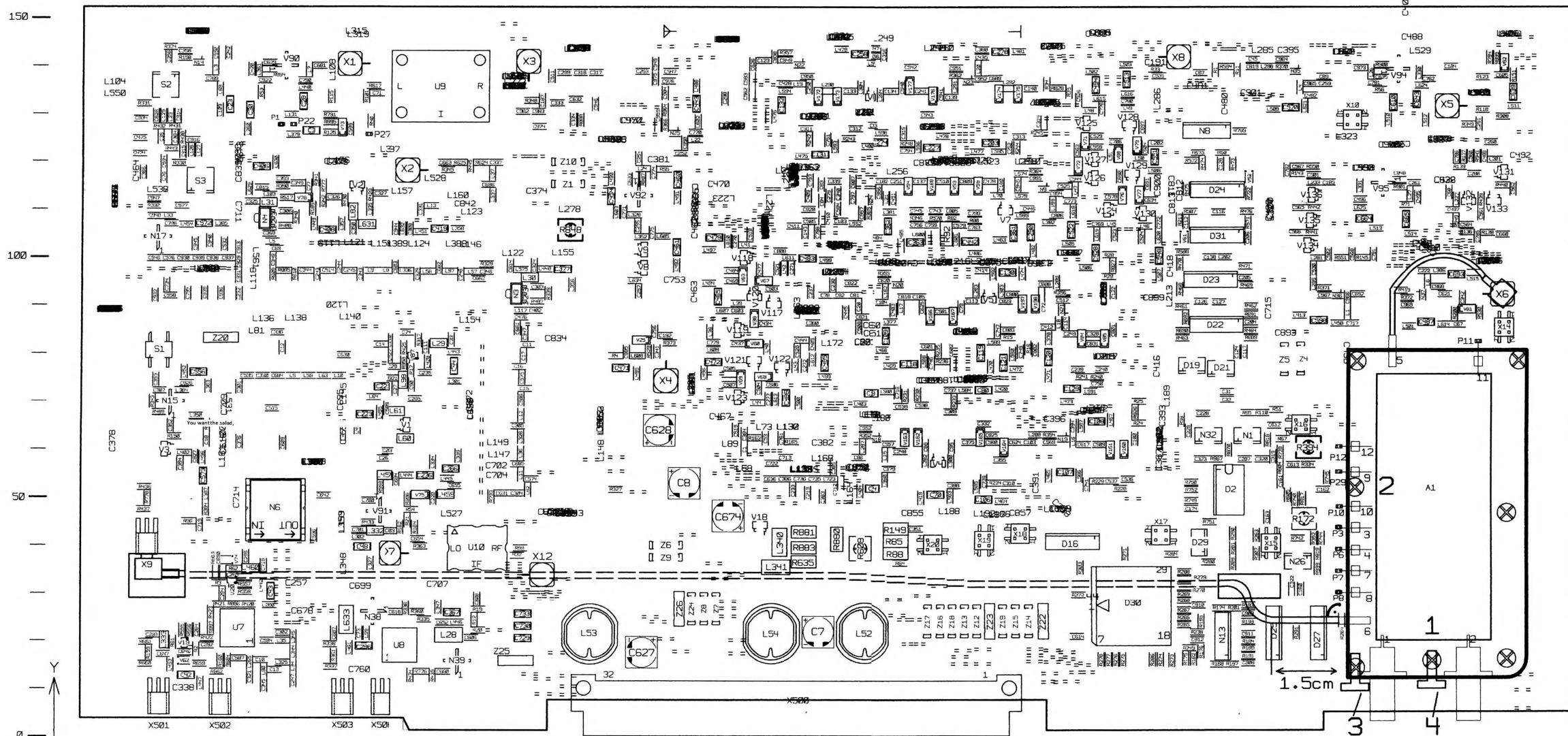

DARSTELLUNG SEITE B
 VIEW ON SIDE B



ACHTUNG: ESD!
 ELEKTROSTATISCH EMPFINDLICHE BAUTEILE ERFORDERN EINE BESONDERE HANDHABUNG.
 ATTENTION: ESD!
 ELECTROSTATIC SENSITIVE DEVICES REQUIRE A SPECIAL HANDLING.

BINDENDE ANGABEN UEBER VARIANTEN, TRIMMWERTE, BAUTEILNUMMERN UND NICHT BESTRICHENE BAUTEILE SIEHE SA.
 FOR BINDING INFORMATION ON MODELS, TRIMMING AN COMPONENT VALUES AND NON-FITTED COMPONENTS SEE PARTS LIST.

ROHDE & SCHWARZ	Benennung: 6-GHZ-ERWEITERUNG 6-GHZ-EXTENSION	Rev./Lang./Netz/C.I.: de	Blatt/Bl.: 06.03 / 1+
Typ: SM10	Datum: 99-08-19	Abteilung: 1GPK	Name: HOFBERGER
Teil-Nr.: 1084.8004			Zusatz-Nr./Drawing No.: 1084.9600.01 D

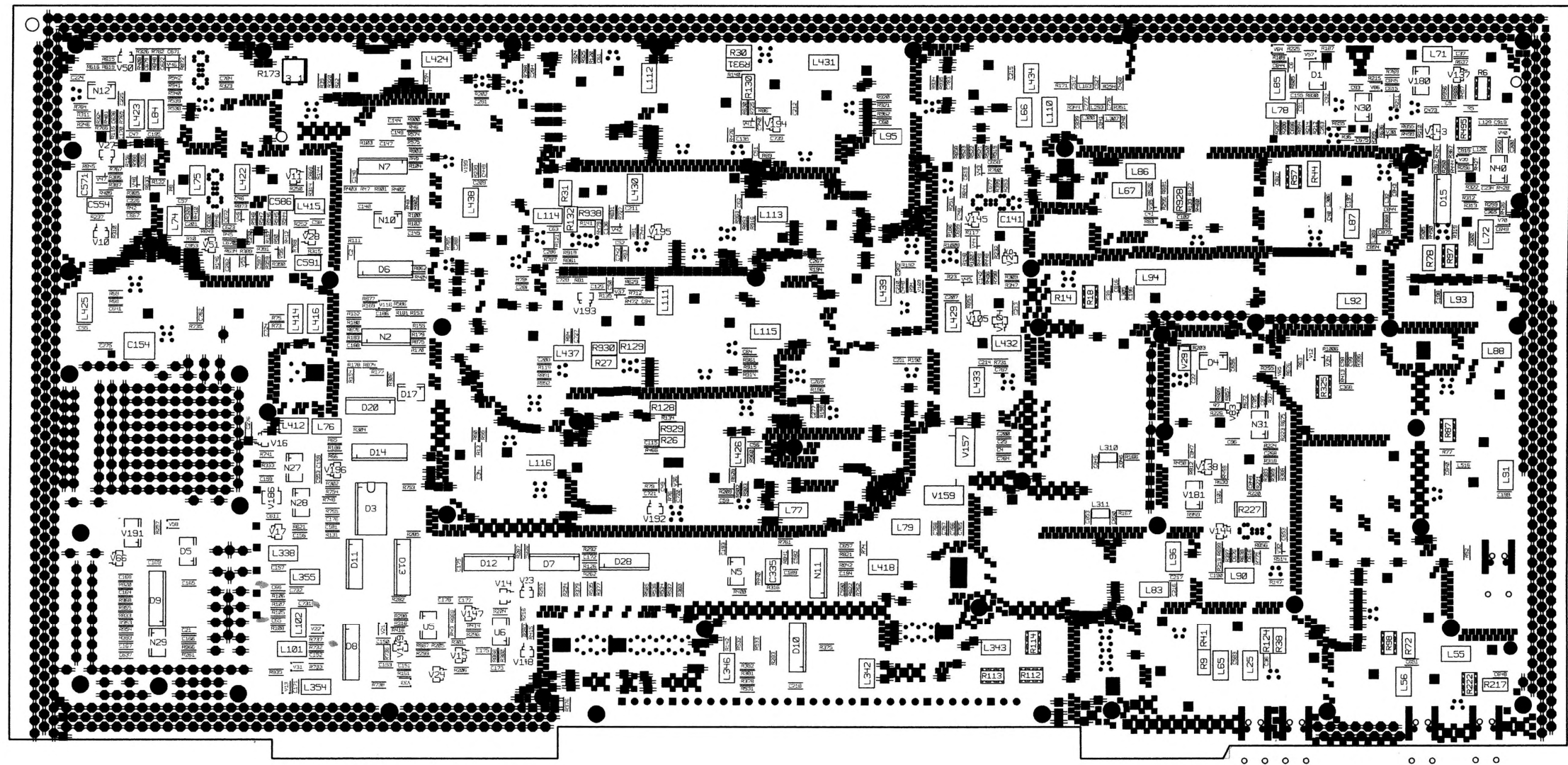

DARSTELLUNG SEITE A
VIEW ON SIDE A



ACHTUNG: EGB1
ELEKTROSTATISCH GEFÄHRDUNG
BEHALDUNGSMITTEL VERMEIDEN
BESONDERE VORSICHT
ATTENTION: ESD!
ELECTROSTATIC SENSITIVE DEVICES
REQUIRE A SPECIAL HANDLING.

ROHDE&SCHWARZ
Typ: SM10
Date: 99-08-19
1084.8004

6-GHZ-ERWEITERUNG
6-GHZ-EXTENSION
Date: 99-08-19
1084.8004

de 06.03 2-
1084.9600.01 D